

Owner's Manual & Safety Instructions

Save This Manual Keep this manual for the safety warnings and precautions, assembly, operating, inspection, maintenance and cleaning procedures. Write the product's serial number in the back of the manual near the assembly diagram (or month and year of purchase if product has no number). Keep this manual and the receipt in a safe and dry place for future reference.



1" X 30"

BELT SANDER



Visit our website at: <http://www.harborfreight.com>
Email our technical support at: tech@harborfreight.com

ITEM 60543

When unpacking, make sure that the product is intact and undamaged. If any parts are missing or broken, please call 1-800-444-3353 as soon as possible.

Copyright© 2012 by Harbor Freight Tools®. All rights reserved.
No portion of this manual or any artwork contained herein may be reproduced in any shape or form without the express written consent of Harbor Freight Tools. Diagrams within this manual may not be drawn proportionally. Due to continuing improvements, actual product may differ slightly from the product described herein. Tools required for assembly and service may not be included.

⚠ WARNING

**Read this material before using this product.
Failure to do so can result in serious injury.
SAVE THIS MANUAL.**

Table of Contents

Safety	2	Maintenance	10
Specifications	5	Parts List and Diagram	11
Setup	5	Warranty	12
Operation	7		





SAFETY

SETUP

OPERATION

MAINTENANCE

WARNING SYMBOLS AND DEFINITIONS

	This is the safety alert symbol. It is used to alert you to potential personal injury hazards. Obey all safety messages that follow this symbol to avoid possible injury or death.
	Indicates a hazardous situation which, if not avoided, will result in death or serious injury.
	Indicates a hazardous situation which, if not avoided, could result in death or serious injury.
	Indicates a hazardous situation which, if not avoided, could result in minor or moderate injury.
	Addresses practices not related to personal injury.

IMPORTANT SAFETY INFORMATION

General Tool Safety Warnings

WARNING

Read all safety warnings and instructions.

Failure to follow the warnings and instructions may result in electric shock, fire and/or serious injury.

Save all warnings and instructions for future reference.

1. KEEP GUARDS IN PLACE and in working order.
2. REMOVE ADJUSTING KEYS AND WRENCHES. Form habit of checking to see that keys and adjusting wrenches are removed from tool before turning it on.
3. KEEP WORK AREA CLEAN. Cluttered areas and benches invite accidents.
4. DON'T USE IN DANGEROUS ENVIRONMENT. Don't use power tools in damp or wet locations, or expose them to rain. Keep work area well lighted.
5. KEEP CHILDREN AWAY. All visitors should be kept safe distance from work area.
6. MAKE WORKSHOP KID PROOF with padlocks, master switches, or by removing starter keys.
7. DON'T FORCE TOOL. It will do the job better and safer at the rate for which it was designed.
8. USE RIGHT TOOL. Don't force tool or attachment to do a job for which it was not designed.

Table A: RECOMMENDED MINIMUM WIRE GAUGE FOR EXTENSION CORDS (120 VOLT)

NAMEPLATE AMPERES (at full load)	EXTENSION CORD LENGTH			
	25'	50'	100'	150'
0 – 6	18	16	16	14
6.1 – 10	18	16	14	12
10.1 – 12	16	16	14	12
12.1 – 16	14	12	Do not use.	

9. USE PROPER EXTENSION CORD. Make sure your extension cord is in good condition. When using an extension cord, be sure to use one heavy enough to carry the current your product will draw. An undersized cord will cause a drop in line voltage resulting in loss of power and overheating. Table A shows the correct size to use depending on cord length and nameplate ampere rating. If in doubt, use the next heavier gauge. The smaller the gauge number, the heavier the cord.

10. **WEAR PROPER APPAREL.** Do not wear loose clothing, gloves, neckties, rings, bracelets, or other jewelry which may get caught in moving parts. Nonslip footwear is recommended. Wear protective hair covering to contain long hair.
11. **ALWAYS USE SAFETY GLASSES.** Also use face or dust mask if sanding operation is dusty. Everyday eyeglasses only have impact resistant lenses, they are NOT safety glasses.
12. **DON'T OVERREACH.**
Keep proper footing and balance at all times.
13. **MAINTAIN TOOLS WITH CARE.** Keep tools clean for best and safest performance. Follow instructions for lubricating and changing accessories.
14. **DISCONNECT TOOLS** before servicing; when changing accessories, such as belts.
15. **REDUCE THE RISK OF UNINTENTIONAL STARTING.** Make sure switch is in off position before plugging in.
16. **USE RECOMMENDED ACCESSORIES.** Consult the owner's manual for recommended accessories. The use of improper accessories may cause risk of injury to persons.
17. **NEVER STAND ON TOOL.**
Serious injury could occur if the tool is tipped or if the belt is unintentionally contacted.
18. **CHECK DAMAGED PARTS.** Before further use of the tool, a guard or other part that is damaged should be carefully checked to determine that it will operate properly and perform its intended function – check for alignment of moving parts, binding of moving parts, breakage of parts, mounting, and any other conditions that may affect its operation. A guard or other part that is damaged should be properly repaired or replaced.
19. **DIRECTION OF FEED.** Feed work into a belt against the direction of rotation of the belt only.
20. **NEVER LEAVE TOOL RUNNING UNATTENDED. TURN POWER OFF.** Don't leave tool until it comes to a complete stop.

Grounding Instructions



⚠ WARNING

TO PREVENT ELECTRIC SHOCK AND DEATH FROM INCORRECT GROUNDING WIRE CONNECTION READ AND FOLLOW THESE INSTRUCTIONS:

110-120 V~ Grounded Tools: Tools with Three Prong Plugs

1. In the event of a malfunction or breakdown, grounding provides a path of least resistance for electric current to reduce the risk of electric shock. This tool is equipped with an electric cord having an equipment-grounding conductor and a grounding plug. The plug must be plugged into a matching outlet that is properly installed and grounded in accordance with all local codes and ordinances.
2. Do not modify the plug provided – if it will not fit the outlet, have the proper outlet installed by a qualified electrician.
3. Improper connection of the equipment-grounding conductor can result in a risk of electric shock. The conductor with insulation having an outer surface that is green with or without yellow stripes is the equipment-grounding conductor. If repair or replacement of the electric cord or plug is necessary, do not connect the equipment-grounding conductor to a live terminal.
4. Check with a qualified electrician or service personnel if the grounding instructions are not completely understood, or if in doubt as to whether the tool is properly grounded.
5. Use only 3-wire extension cords that have 3-prong grounding plugs and 3-pole receptacles that accept the tool's plug.
6. Repair or replace damaged or worn cord immediately.

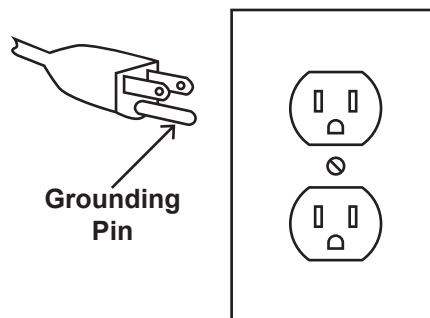

**125 V~ 3-Prong Plug and Outlet
(for up to 125 V~ and up to 15 A)**

7. This tool is intended for use on a circuit that has an outlet that looks like the one illustrated above in **125 V~ 3-Prong Plug and Outlet**. The tool has a grounding plug that looks like the plug illustrated above in **125 V~ 3-Prong Plug and Outlet**.
8. The outlet must be properly installed and grounded in accordance with all codes and ordinances.
9. Do not use an adapter to connect this tool to a different outlet.

Sander Safety Warnings

For Your Own Safety Read Instruction Manual Before Operating Sander

1. Wear eye protection.
2. Support workpiece with miter gauge, backstop, or worktable.
3. Maintain 1/16 inch maximum clearance between table and sanding belt or disc.
4. The backstop is a fence near the surface that helps the operator maintain control of the workpiece and prevents the workpiece from being pulled into the machine. For safety, it must be adjusted very close to the sanding surface.
5. The worktable is the surface mounted close to the sanding surface that the operator rests the workpiece against to prevent it from being pulled by the sanding surface. For safety, it must be adjusted very close to the sanding surface.
6. The sanding belt is designed to rotate down towards the table while the disc rotates both up from the table and down towards the table.
7. **DO NOT OPERATE WITH ANY GUARD DISABLED, DAMAGED, OR REMOVED. Moving guards must move freely and close instantly.**
8. The use of accessories or attachments not recommended by the manufacturer may result in a risk of injury to persons.
9. When servicing use only identical replacement parts.
10. Do not depress the spindle lock when starting or during operation.
11. Only use safety equipment that has been approved by an appropriate standards agency. Unapproved safety equipment may not provide adequate protection. Eye protection must be ANSI-approved and breathing protection must be NIOSH-approved for the specific hazards in the work area.
12. Stay alert, watch what you are doing and use common sense when operating a power tool. Do not use a power tool while you are tired or under the influence of drugs, alcohol or medication. A moment of inattention while operating power tools may result in serious personal injury.
13. Industrial applications must follow OSHA guidelines.
14. Maintain labels and nameplates on the tool. These carry important safety information. If unreadable or missing, contact Harbor Freight Tools for a replacement.
15. Avoid unintentional starting. Prepare to begin work before turning on the tool.
16. People with pacemakers should consult their physician(s) before use. Electromagnetic fields in close proximity to heart pacemaker could cause pacemaker interference or pacemaker failure.
17. **WARNING:** Some dust created by power sanding, sawing, grinding, drilling, and other construction activities, contains chemicals known [to the State of California] to cause cancer, birth defects or other reproductive harm. Some examples of these chemicals are:
 - Lead from lead-based paints
 - Crystalline silica from bricks and cement or other masonry products
 - Arsenic and chromium from chemically treated lumberYour risk from these exposures varies, depending on how often you do this type of work. To reduce your exposure to these chemicals: work in a well ventilated area, and work with approved safety equipment, such as those dust masks that are specially designed to filter out microscopic particles. (California Health & Safety Code § 25249.5, *et seq.*)
18. **WARNING:** Handling the cord on this product will expose you to lead, a chemical known to the State of California to cause cancer, and birth defects or other reproductive harm. Wash hands after handling. (California Health & Safety Code § 25249.5, *et seq.*)
19. The warnings, precautions, and instructions discussed in this instruction manual cannot cover all possible conditions and situations that may occur. It must be understood by the operator that common sense and caution are factors which cannot be built into this product, but must be supplied by the operator.

Vibration Safety

This tool vibrates during use. Repeated or long-term exposure to vibration may cause temporary or permanent physical injury, particularly to the hands, arms and shoulders. To reduce the risk of vibration-related injury:

1. Anyone using vibrating tools regularly or for an extended period should first be examined by a doctor and then have regular medical check-ups to ensure medical problems are not being caused or worsened from use. Pregnant women or people who have impaired blood circulation to the hand, past hand injuries, nervous system

disorders, diabetes, or Raynaud's Disease should not use this tool. If you feel any medical or physical symptoms related to vibration (such as tingling, numbness, and white or blue fingers), seek medical advice as soon as possible.

2. Do not smoke during use. Nicotine reduces the blood supply to the hands and fingers, increasing the risk of vibration-related injury.

3. Use tools with the lowest vibration when there is a choice between different processes.
4. Include vibration-free periods each day of work.
5. Grip workpiece as lightly as possible (while still keeping safe control of it). Let the tool do the work.
6. To reduce vibration, maintain the tool as explained in this manual. If any abnormal vibration occurs, stop use immediately.



SAVE THESE INSTRUCTIONS.

Specifications

Electrical Rating	120V~ / 60Hz / 2A
Belt Speed	3260 FPM
Belt Size	1" x 30"
Dust Port	1-3/4" OD



Setup - Before Use:



Read the **ENTIRE IMPORTANT SAFETY INFORMATION** section at the beginning of this manual including all text under subheadings therein before set up or use of this product.

Functions

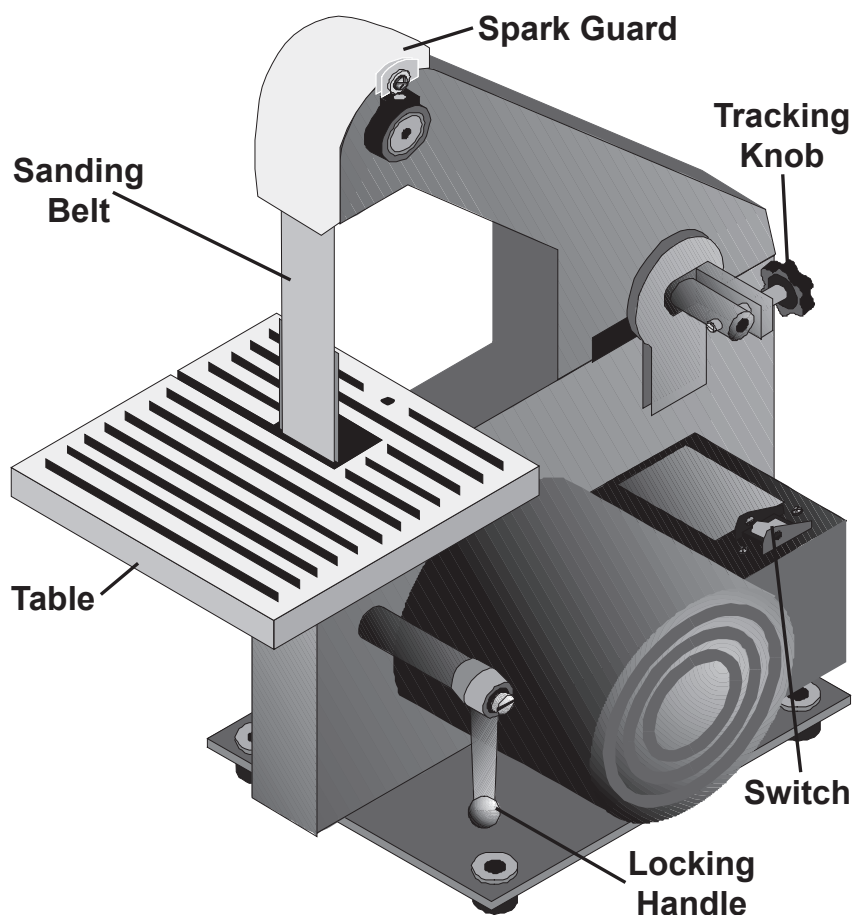

Assembly

⚠ WARNING

TO PREVENT SERIOUS INJURY FROM ACCIDENTAL OPERATION:
Turn the Power Switch of the tool off and unplug the tool from its electrical outlet before performing any procedure in this section.

Note: For additional information regarding the parts listed in the following pages, refer to the Assembly Diagram near the end of this manual.

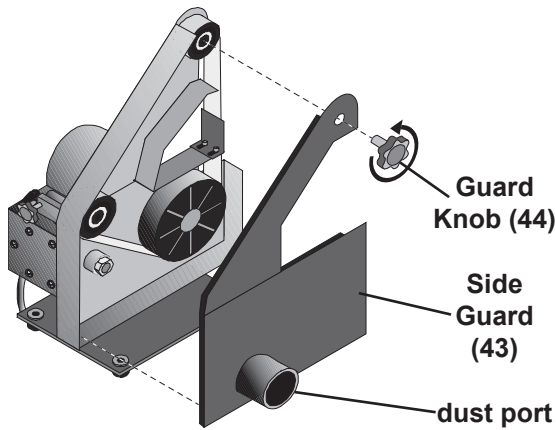

Figure A: Side Guard (43) removal

1. Remove Guard Knob (44) and take off the Side Guard (43). See Figure A.
2. Remove the Bolt (45) from the Locking Handle (29). See Figure B.

Note: Do not lose the Toothed Washer (27) under the Locking Handle (29).

3. Place the Table (40) on the Frame (14) so that the Sanding Belt (42) fits through the slot in the Table. See Figure B.
4. Replace the Bolt (45) and secure it using the Toothed Washer (27) and Locking Handle (29). See Figure B.

5. Replace the Side Guard (43) and secure it using the Guard Knob (44).

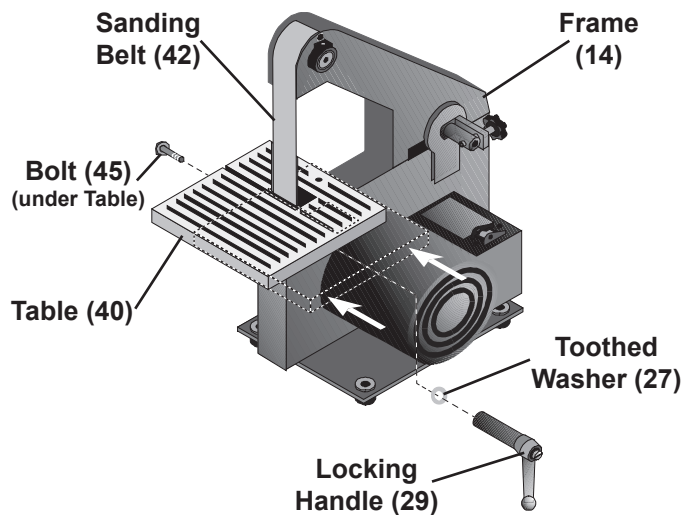

Figure B: Table (40) installation

6. Loosen the Screw (32) shown in Figure C.
7. Place the Spark Guard (34) on the top of the Frame and secure using the Screw (32). See Figure C
8. Place the Belt Sander on a secure workbench able to carry the weight of the Belt Sander and stock.
9. Attach the vacuum hose (if used) to the 1-3/4" dust port on the Side Guard. See Figure A. Otherwise, attach a vacuum bag (not supplied) to the port to collect the dust.

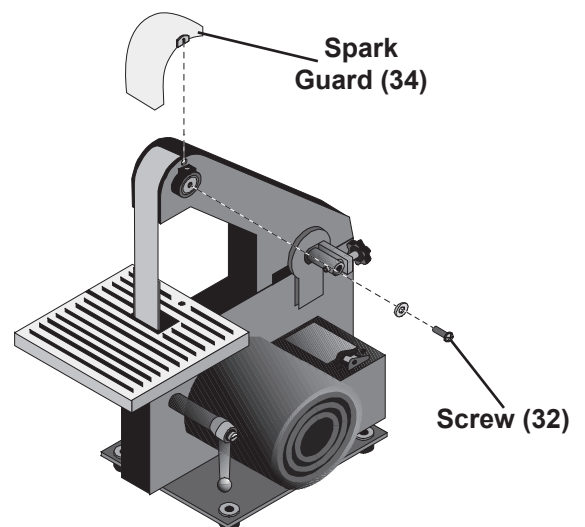

Figure C: Spark Guard (34) installation

Operating Instructions



Read the **ENTIRE IMPORTANT SAFETY INFORMATION** section at the beginning of this manual including all text under subheadings therein before set up or use of this product.

Tool Set Up

WARNING

TO PREVENT SERIOUS INJURY FROM ACCIDENTAL OPERATION:
Turn the Power Switch of the tool off and unplug the tool from its electrical outlet before performing any procedure in this section.

TO PREVENT SERIOUS INJURY:
DO NOT OPERATE WITH ANY GUARD DISABLED, DAMAGED, OR REMOVED.
Moving guards must move freely and close instantly.

Removing and Installing Sanding Belt

1. Remove the Guard Knob (44), then remove the Side Guard (43).
2. Turn the Tracking Knob (18) counterclockwise to loosen the Sanding Belt (42).
3. Remove the Sanding Belt.
4. Place the new Sanding Belt on the three pulleys. Center the Sanding Belt on the pulleys.
5. Tighten the Sanding Belt by turning the Tracking Knob clockwise until the rear Driven Wheel (10) appears centered.
6. Replace the Side Guard and Guard Knob.
7. Check and adjust Sanding Belt tracking before use as explained in the following section.

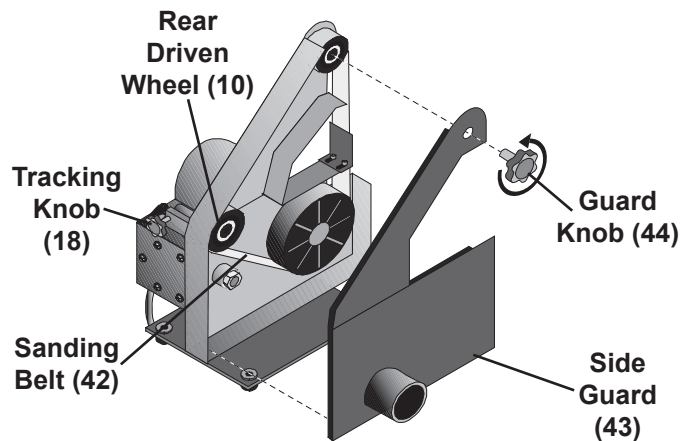

Figure D: Sanding Belt (42) access

Adjusting the Sanding Belt Tracking

1. Turn the Belt Sander on.
2. Look at the Sanding Belt (42) through the Spark Guard (34):
 - a. If it is riding on the **center** of the upper Driven Wheel (10) the tracking is correct and **no further adjustment** is required.
 - b. If the Belt rides to the **left**, turn the Tracking Knob (18) gradually **counterclockwise** until the Belt is centered.
 - c. If the Belt rides to the **right**, turn the Tracking Knob (18) gradually **clockwise** until the Belt is centered.

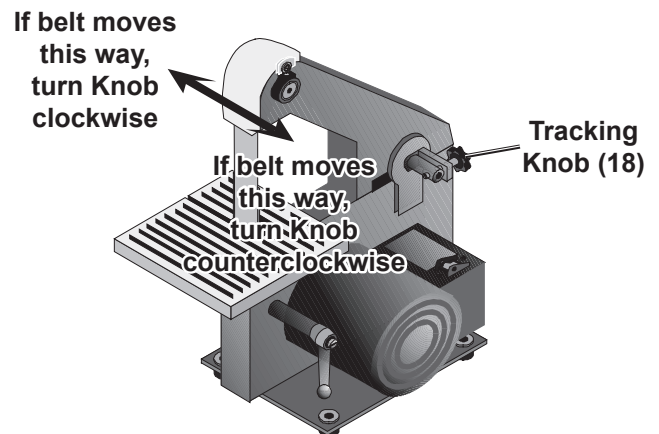

Figure E: Tracking Adjustment

Adjustment of Belt Support

1. Remove the Table (40) by removing the Bolt (45) and Locking Handle (29), as shown.
2. Loosen the two Cap Screws (38) on the Belt Support (35).
3. Adjust the Belt Support to no farther than 1/16" from the back of the Sanding Belt.
4. Tighten the two Cap Screws on the Belt Support.
5. Replace the Table and tighten it in place.

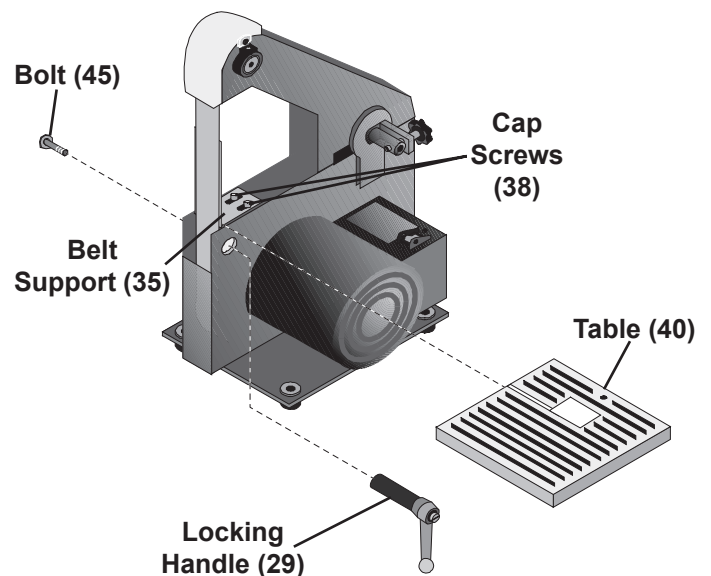

Figure F: Belt Support (35) access

Adjusting Table Angle

1. Loosen the Locking Handle (29) by turning it counterclockwise.
2. Tilt the Table (40) to the desired angle: Use a protractor to ensure accuracy. There should be no more than 1/16" distance between the Table and the Sanding Belt (42).
3. Tighten the Locking Handle.

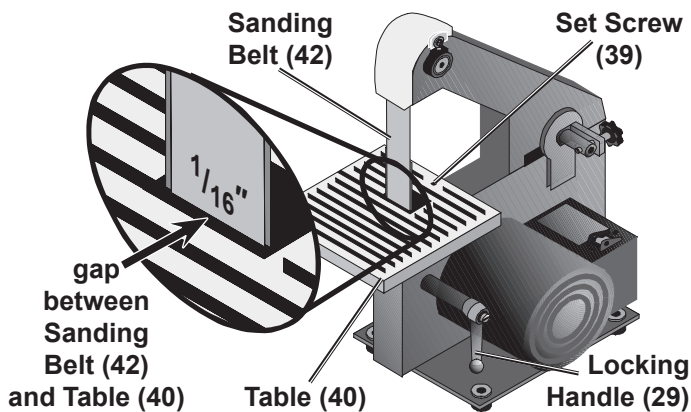

Figure G: Table (40) gap

Leveling the Table

1. Loosen the Locking Handle (29) by turning it counterclockwise, and lean the table as far back as possible.
2. Using a square (sold separately), verify that the Table is 90° to the belt.
3. If the Table is tilted toward the front of the machine, tighten the Set Screw (39).
4. If the Table is tilted toward the back of the machine, loosen the Set Screw.
5. Tighten the Locking Handle.



Workpiece and Work Area Set Up

1. Designate a work area that is clean and well-lit. The work area must not allow access by children or pets to prevent distraction and injury.
2. Route the power cord along a safe route to reach the work area without creating a tripping hazard or exposing the power cord to possible damage. The power cord must reach the work area with enough extra length to allow free movement while working.
3. There must not be objects, such as utility lines, nearby that will present a hazard while working.

General Operating Instructions

Note: The Belt Sander is designed to sand only workpieces made of wood.

CAUTION! Do not sand stock that is too small to be safely supported or held. Sand those pieces by hand.

1. Plug Sander into wall socket (or extension cord) containing grounding prong.
2. Turn on Power Switch momentarily to verify that Sanding Belt is tracking properly. If Belt tracking needs adjustment, turn Belt Sander off and refer to instructions on page 7. If the Sanding Belt is rotating properly with proper tracking, the Belt Sander is ready for use.

3. Turn on Power Switch.
4. Push workpiece against belt gradually to start sanding. Keep hands clear and do not apply excessive force.

CAUTION! Do not apply so much pressure on object being sanded to inhibit rotation of sanding belt. Keep fingers away from the sanding belt.

5. To prevent accidents, turn off the tool and disconnect its power supply after use. Clean, then store the tool indoors out of children's reach.



Maintenance and Servicing



Procedures not specifically explained in this manual must be performed only by a qualified technician.

WARNING

TO PREVENT SERIOUS INJURY FROM ACCIDENTAL OPERATION:

Turn the Power Switch of the tool off and unplug the tool from its electrical outlet before performing any procedure in this section.

TO PREVENT SERIOUS INJURY FROM TOOL FAILURE:

Do not use damaged equipment. If abnormal noise or vibration occurs, have the problem corrected before further use.

Cleaning, Maintenance, and Lubrication

- BEFORE EACH USE**, inspect the general condition of the tool. Check for:
 - loose hardware,
 - misalignment or binding of moving parts,
 - cracked or broken parts,
 - damaged electrical wiring, and
 - any other condition that may affect its safe operation.
- AFTER USE**, wipe external surfaces of the tool with clean cloth.
- Replace Sanding Belts when they become torn or worn down to the paper.
- WARNING!** If the supply cord of this power tool is damaged, it must be replaced only by a qualified service technician.

Troubleshooting

Problem	Possible Causes	Likely Solutions
Tool will not start.	<ol style="list-style-type: none">Cord not connected.No power at outlet.Internal damage or wear. (Carbon brushes or switch, for example.)	<ol style="list-style-type: none">Check that cord is plugged in.Check power at outlet. If outlet is unpowered, turn off tool and check circuit breaker. If breaker is tripped, make sure circuit is right capacity for tool and circuit has no other loads.Have technician service tool.
Tool operates slowly.	Extension cord too long or wire size too small.	Eliminate use of extension cord. If an extension cord is needed, use one with the proper diameter for its length and load. See Table A on page 2.
Performance decreases over time.	<ol style="list-style-type: none">Belt dull or damaged.Carbon brushes worn or damaged.	<ol style="list-style-type: none">Replace as needed.Have qualified technician replace brushes.
Excessive noise or rattling.	Internal damage or wear. (Carbon brushes or bearings, for example.)	Have technician service tool.
Overheating.	<ol style="list-style-type: none">Forcing machine to work too fast.Accessory dull or damaged.Blocked motor housing vents.Motor being strained by long or small diameter extension cord.	<ol style="list-style-type: none">Allow machine to work at its own rate.Keep cutting accessories sharp. Replace as needed.Wear ANSI-approved safety goggles and NIOSH-approved dust mask/respirator while blowing dust out of motor using compressed air.Eliminate use of extension cord. If an extension cord is needed, use one with the proper diameter for its length and load. See Table A on page 2.



Follow all safety precautions whenever diagnosing or servicing the tool. Disconnect power supply before service.

Parts List and Diagram

Part	Description	Qty
1	Bolt M8 x 20	2
2	Spring Washer 8	2
3	Flat Washer 8	2
4	Rubber Feet	4
5	Base	1
6	Set Screw M6 x 10	2
7	Retaining Ring 15	2
8	Ball Bearing 6202	2
9	Driving Wheel	1
10	Driven Wheel	2
11	Countersunk Bolt M6 x 12	3
12	Lock Nut M10	1
13	Flat Washer 10	2
14	Frame	1
15	Pulley Axle B	1
16	Locking Handle	1
17	Spring A	1
18	Tracking Knob	1
19	Bolt M10 x 30	1
20	Spring Pin 3 x 18	1
21	Flat Washer 5	2
22	Spring B	1
23	Split Washer 4	1

Part	Description	Qty
24	Motor	1
25	Cushion	1
26	Spring C	1
27	Toothed Washer 8	1
28	Tension Axle	1
29	Locking Handle	1
30	Spring	1
31	Screw	1
32	Bolt M4 x 10	1
33	Flat Washer 4	1
34	Spark Guard	1
35	Belt Support	1
36	Flat Washer 4	2
37	Elastic Washer 4	2
38	Cap Screw M4 x 12	2
39	Set Screw M6 x 16	1
40	Table	1
41	Pulley Axle A	1
42	Sanding Belt 1" x 30"	1
43	Side Guard	1
44	Guard Knob	1
45	Bolt M8 x 20	1

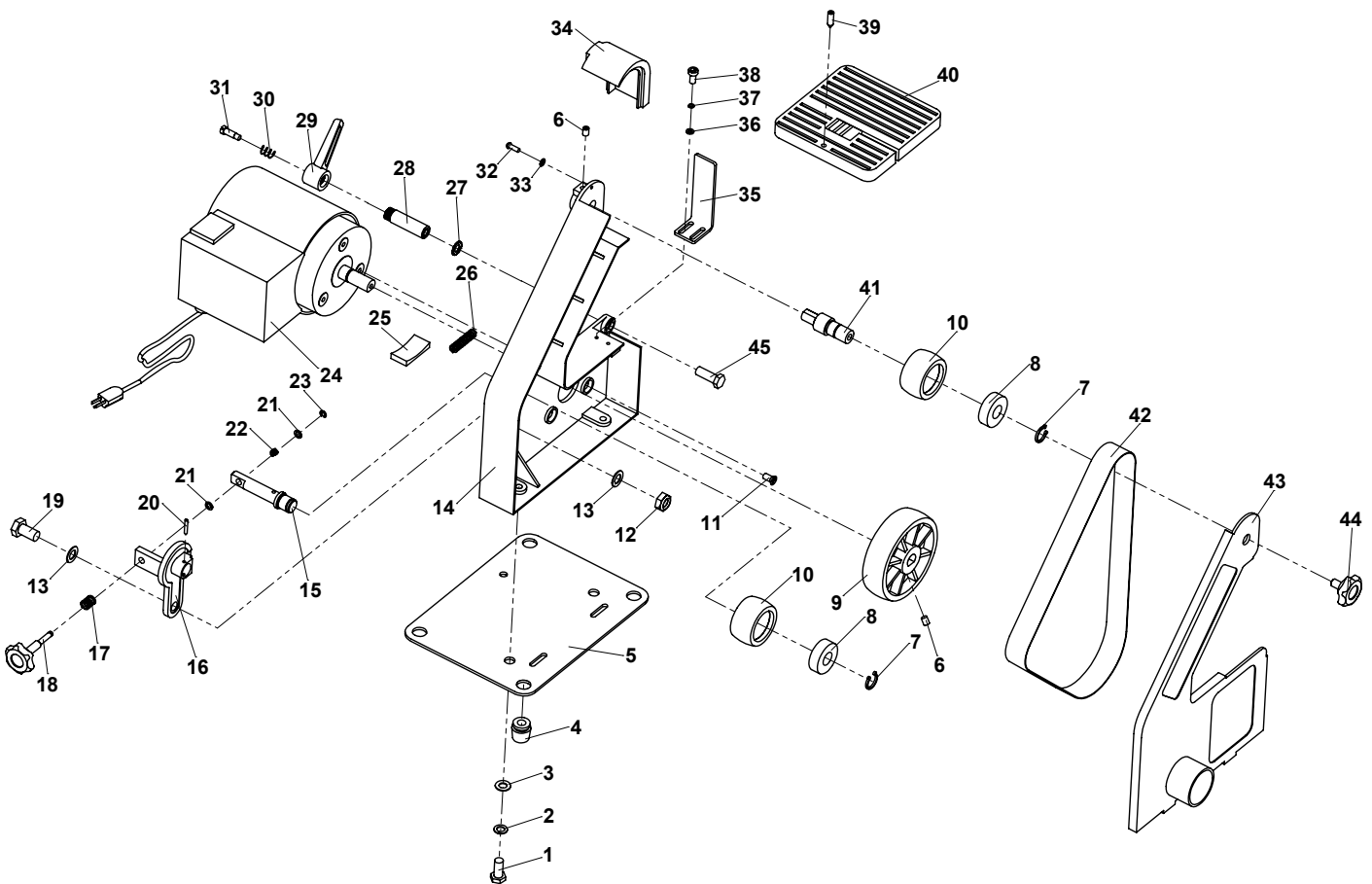

Record Product's Serial Number Here: _____

Note: If product has no serial number, record month and year of purchase instead.

Note: Some parts are listed and shown for illustration purposes only, and are not available individually as replacement parts.

PLEASE READ THE FOLLOWING CAREFULLY

THE MANUFACTURER AND/OR DISTRIBUTOR HAS PROVIDED THE PARTS LIST AND ASSEMBLY DIAGRAM IN THIS MANUAL AS A REFERENCE TOOL ONLY. NEITHER THE MANUFACTURER OR DISTRIBUTOR MAKES ANY REPRESENTATION OR WARRANTY OF ANY KIND TO THE BUYER THAT HE OR SHE IS QUALIFIED TO MAKE ANY REPAIRS TO THE PRODUCT, OR THAT HE OR SHE IS QUALIFIED TO REPLACE ANY PARTS OF THE PRODUCT. IN FACT, THE MANUFACTURER AND/OR DISTRIBUTOR EXPRESSLY STATES THAT ALL REPAIRS AND PARTS REPLACEMENTS SHOULD BE UNDERTAKEN BY CERTIFIED AND LICENSED TECHNICIANS, AND NOT BY THE BUYER. THE BUYER ASSUMES ALL RISK AND LIABILITY ARISING OUT OF HIS OR HER REPAIRS TO THE ORIGINAL PRODUCT OR REPLACEMENT PARTS THERETO, OR ARISING OUT OF HIS OR HER INSTALLATION OF REPLACEMENT PARTS THERETO.

Limited 90 Day Warranty

Harbor Freight Tools Co. makes every effort to assure that its products meet high quality and durability standards, and warrants to the original purchaser that this product is free from defects in materials and workmanship for the period of 90 days from the date of purchase. This warranty does not apply to damage due directly or indirectly, to misuse, abuse, negligence or accidents, repairs or alterations outside our facilities, criminal activity, improper installation, normal wear and tear, or to lack of maintenance. We shall in no event be liable for death, injuries to persons or property, or for incidental, contingent, special or consequential damages arising from the use of our product. Some states do not allow the exclusion or limitation of incidental or consequential damages, so the above limitation of exclusion may not apply to you. THIS WARRANTY IS EXPRESSLY IN LIEU OF ALL OTHER WARRANTIES, EXPRESS OR IMPLIED, INCLUDING THE WARRANTIES OF MERCHANTABILITY AND FITNESS.

To take advantage of this warranty, the product or part must be returned to us with transportation charges prepaid. Proof of purchase date and an explanation of the complaint must accompany the merchandise. If our inspection verifies the defect, we will either repair or replace the product at our election or we may elect to refund the purchase price if we cannot readily and quickly provide you with a replacement. We will return repaired products at our expense, but if we determine there is no defect, or that the defect resulted from causes not within the scope of our warranty, then you must bear the cost of returning the product.

This warranty gives you specific legal rights and you may also have other rights which vary from state to state.

