



Hardware Installation Manual

MX4660

4-Axis Stepper Drive with Breakout Board & I/O's



Revision 1.1

03 / 2015

<http://www.Leadshine.com>
<http://www.Leadshineusa.com>

©2015 Leadshine Technology Co., Ltd.

Notice

Read this manual carefully and the MX4660 datasheet before any assembling and using. Incorrect handling of products in this manual can result in injury and damage to persons and machinery. Strictly adhere to the technical information regarding installation requirements.

This manual is not for use or disclosure outside of Leadshine except under permission. All rights are reserved. No part of this manual shall be reproduced, stored in retrieval form, or transmitted by any means, electronic, mechanical, photocopying, recording, or otherwise without approval from Leadshine. While every precaution has been taken in the preparation of the book, Leadshine assumes no responsibility for errors or omissions. Neither is any liability assumed for damages resulting from the use of the information contained herein.

This document is proprietary information of Leadshine that is furnished for customer use ONLY. Information in this document is subject to change without notice and does not represent a commitment on the part of Leadshine. Therefore, information contained in this manual may be updated from time-to-time due to product improvements, etc., and may not conform in every respect to former issues.

Record of Revisions

Revision	Date	Description of Release
<i>1.0</i>	<i>10/2014</i>	<i>Initial Release</i>
<i>1.1</i>	<i>03/2015</i>	<i>Update description for the connections of the power supply, digital inputs and outputs</i>

Contents

1. INTRODUCTION	4
2. FEATURES	5
3. APPLICATIONS	5
4. BLOCK DIAGRAM	5
5. DIMENSIONS	7
6. GET STARTED	7
7. CONNECTING A POWER SUPPLY	8
8. CONNECTING STEPPER MOTORS	8
8.1. CONNECTING A 4-LEAD STEPPER MOTOR	8
8.2. CONNECTING A 6-LEAD STEPPER MOTOR	9
8.2.1. CONNECTING A 6-LEAD STEPPER MOTOR IN SERIES CONNECTION	9
8.2.2. CONNECTING A 6-LEAD STEPPER MOTOR IN SERIES CONNECTION	9
8.3. CONNECTING A 8-LEAD STEPPER MOTOR	10
8.3.1. CONNECTING A 8-LEAD STEPPER MOTOR IN SERIES CONNECTION	10
8.3.2. CONNECTING A 8-LEAD STEPPER MOTOR IN PARALLEL CONNECTION	10
9. CONNECTING AN E-STOP SWITCH OR SHORTING THE CONNECTION	11
10. ENABLING / DISABLING CHARGE PUMP	11
11. SETTING THE "SMOOTHER" SWITCH	12
12. CONFIGURING OUTPUT CURRENT AND MICRO STEP	12
12.1. CONFIGURING THE OUTPUT CURRENT	12
12.2. CONFIGURING THE OUTPUT CURRENT	13
13. CONNECTING THE DB25 CONNECTOR	13
13.1. CONNECTING THE DB25 STEP & DIRECTION PINS	13
13.2. CONNECTING THE DB25 FAULT OUTPUT PIN	14
13.3. CONNECTING THE DB25 CHARGE PUMP PIN	15
13.4. CONNECTING THE PWM PIN	15
14. OPTIONAL CONNECTIONS FOR INPUTS/OUTPUTS	15
14.1. CONNECTING THE DIGITAL INPUTS	15
14.2. CONNECTING THE DIGITAL OUTPUTS	16
14.3. CONNECTING THE ANALOG OUTPUT	18
APPENDIX A: MX4660 CONNECTION DIAGRAM	20
APPENDIX B: DB25 CONNECTOR PINOUT	20
APPENDIX D: DIGITAL INPUTS	23
APPENDIX E: DIGITAL OUTPUTS	25
APPENDIX F: OPTO-ISOLATED ANALOG OUTPUT	26
APPENDIX G: STEPPER DRIVE MODULE REPLACEMENT	26
APPENDIX H: WARRANTY INFORMATION	26
APPENDIX I: TROUBLE SHOOTING	26
CONTACT US	28

Introduction

Thank you for choosing the Leadshine MX4660, a high performance 4-Axis stepper drive with built-in breakout board and I/O's based on the latest DSP technology. It is specially designed to allow **EASY** and **RAPID** implementation for full control of 4 stepper motors of frame sizes 17, 23, 24, or 34. By taking step & direction commands, the MX4660 can be easily controlled by motion controllers, PLC's, CNC software (e.g. Mach 3/4, EMC).... This makes it ideal for many applications in industries such as CNC machinery (CNC routers, plasma, mills, laser welders, machining centers, jewelry mills...), electronics, semi-conductor, medical, textile, etc. for easy, quick and cost-effective implementation.

Based on the latest DSP technology and Leadshine's advance stepper control algorithm, the MX4660 adopts features such as anti-resonance, multi-stepping, input pulse smoothing, automatic idle current reduction ... It offers high precision, excellent torque, extra low noise, very low motor heating, and smooth driven motor movement. With the working voltage of 20-60VDC and output current up to 6.0A, the MX4660 can drive 4 two-phases stepper motors from NEMA 17 to 34 in full power with high reliability.

The MX4660 is easy to configure without the use of software. With the four DIP switches (one for each axis), a user can easily configure the output current to one of the eight 1.41-6.0A settings, and the micro stepping resolution to one of the eight 200-12,800 (full to 1/64 step) settings. Each axis can have its configurations different from any of other axes to meet its own control requirements.

A Leadshine MX4660 stepper drive has one E-Stop input, one analog input (0-10 VDC), one fault output, 8 general digital inputs, and 6 general digital outputs. This allows quick and easy I/O connections such as E-Stop, home/limit switches, VFD..., to save installation space & time, minimize wiring, increase system reliability, and cut costs. Through the 4 high-speed general digital outputs (200 kHz), the MX4660 also allows control expansion for 2 additional axes, which is ideal to control 5-axis and 6-axis machines/devices.

The MX4660 adopts modular design with 4 individual stepper drive boards. If any the drive boards malfunctions, a user can easily replace it with a SDM660 stepper drive module at minimal cost.



The MX4660 can also be used to power 4-phase (0.9°) stepper motors. But in this case, there will be 400 full steps needed for each revolution. You need to make sure that the settings in your controller (motion controller, PLC, CNC control system...) are properly configured to reflect this requirement.

Features

- Full control for up to 4 stepper motors of NEMA 17, 23, 24, or 34
- Sophisticated stepper motor control based on the latest DSP technology
- Built-in breakout board and I/O's
- Step & direction control
- Input pulse smoothing for less jittering, higher torque, and quicker response
- Extra low motor heating & noise
- Extra smooth motor movement
- Easy setup and quick configuration
- Compact size & easy setup
- 200 KHz maximum frequency for each axis
- 20-60 VDC operating voltage
- Convenient individual setting for each axis via DIP switches
- 8 micro step settings of 200-12,800 (full to 1/64) for each axis
- 8 output current settings of 1.41 - 6.0A for each axis
- E-Stop input
- Fault output
- 8 general digital inputs including 4 high-speed (200 kHz) ones for 5th and 6th axis control
- 6 general digital outputs
- Two 12 VDC auxiliary power outputs
- Automatic idle current reduction to 50%

Applications

The Leadshine MX4660 4-axis stepper drive can be easily and rapidly implemented in stepper control systems for OEM applications such as CNC routers / engravers, CNC mills, CNC Cutters, Laser Welders, CNC waterjets, X-Y tables, dispensing machines, medical equipment, scientific instruments...

Its unique design with built-in breakout board and I/O's fits seamlessly in many applications powered by many popular CNC systems such as Mach3, Mach4, EMC, WinCNC, etc.

Block Diagram

The figure1 shows MX4660 main internal components and how it interfaces with other components in the motion control system of your machine/device.

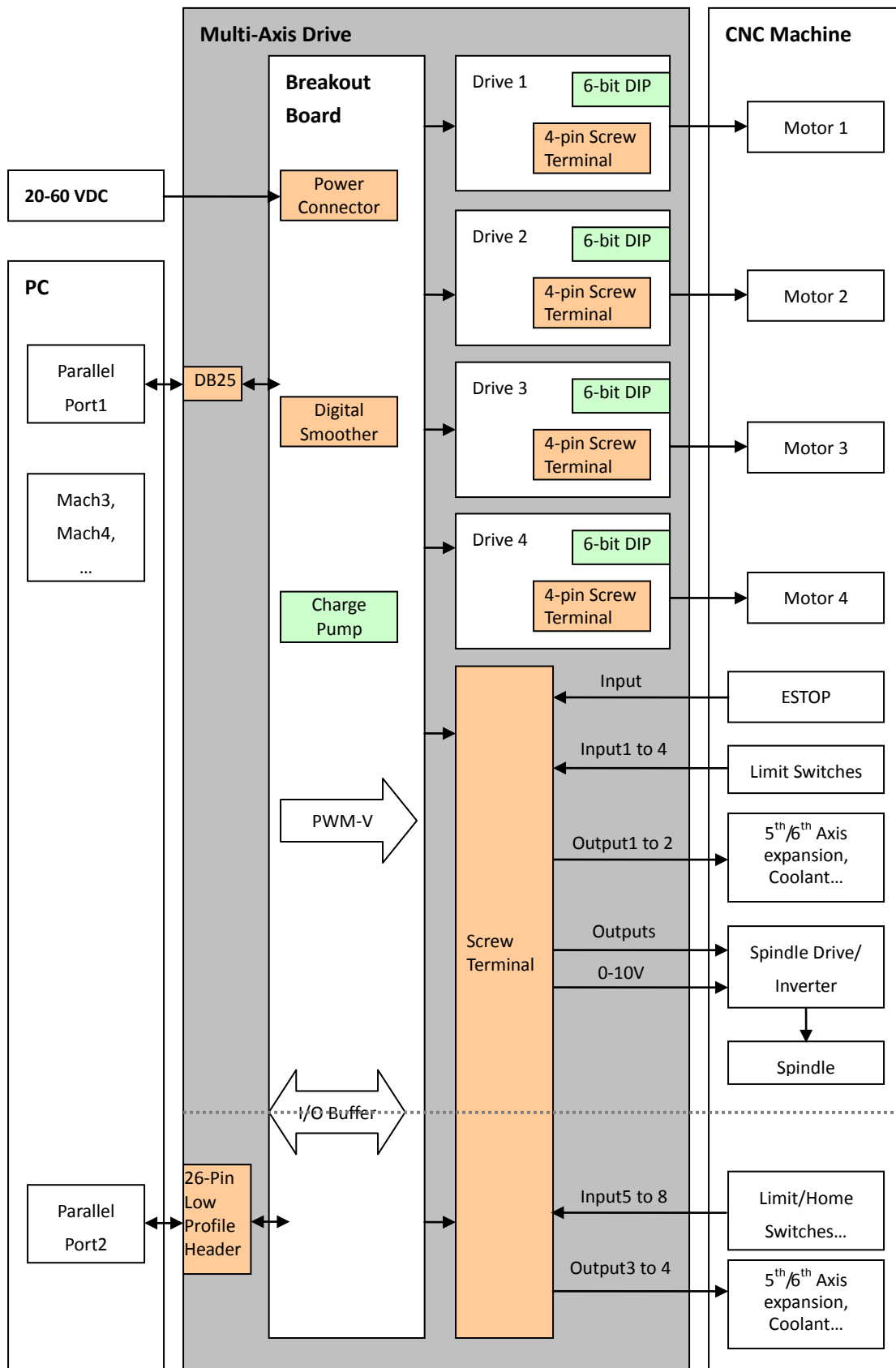

Figure 1 MX4660 Block diagram

Dimensions

Unit: mm (1 inch = 25.4 mm)

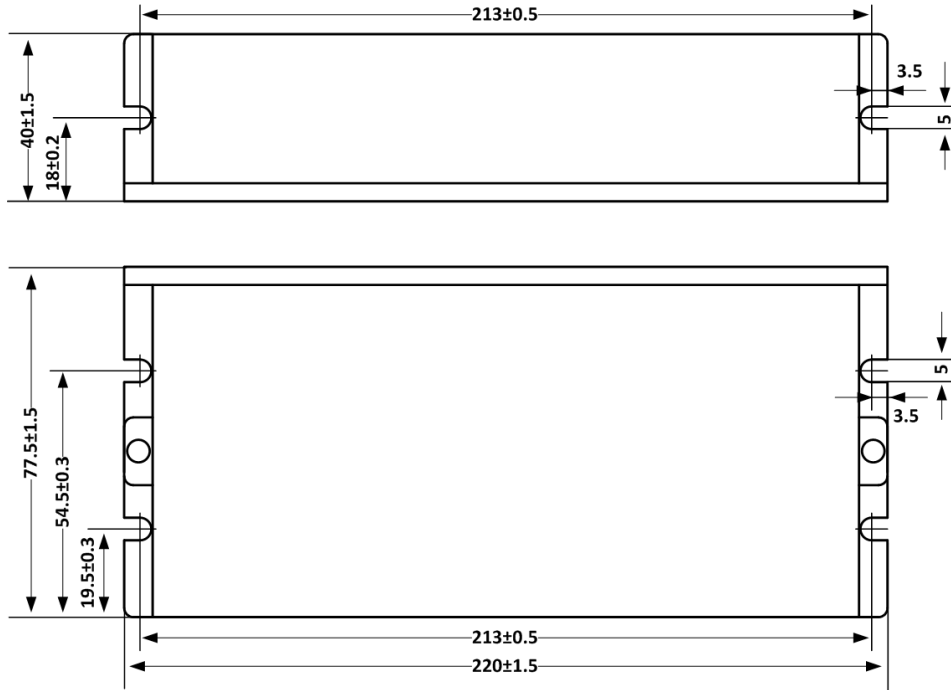

Figure 2 MX4660 dimensions

Get Started

Before you start hardware connection, refer to the following MX4660 layout diagram (figure 3) for connector/DIP switch location. Read the MX4660 datasheet for each connector explanation. Then, get the following prepared:

- A 24-54 VDC power supply.
- Up to 4 stepper motors depending on how many axes that MX4660 will power in your application.
- A source of step signals, such as a motion controller, PLC, or a PC-based control system (Mach 3, EMC, etc.).
- A small flat blade screw driver for tightening the screw connectors of the MX4660.
- Whatever optional external devices needed to be controlled through the built-in outputs and inputs.

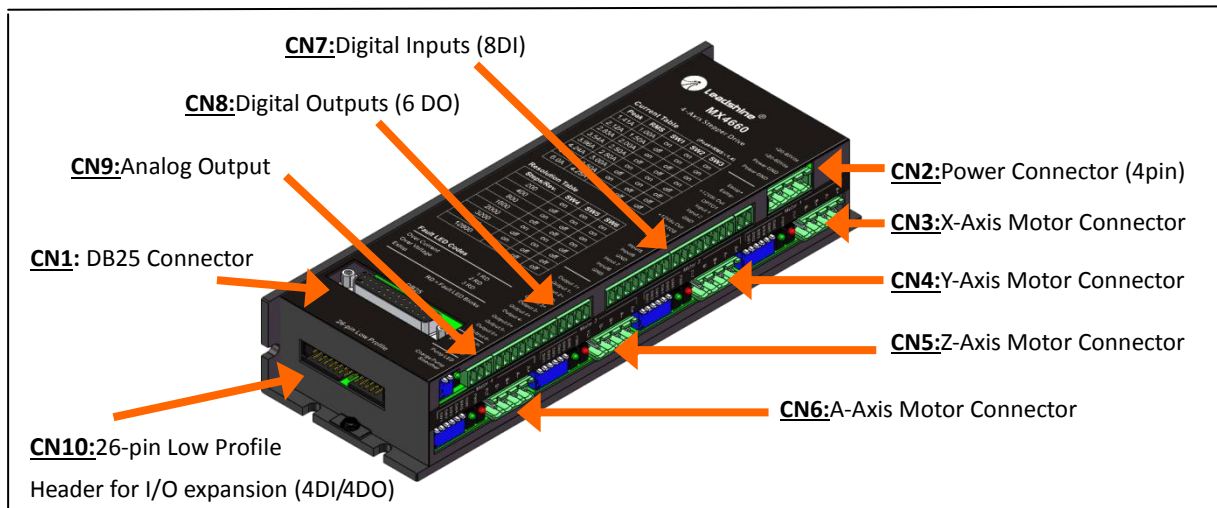

Figure 3 MX4660 layout

Connecting a Power Supply

The power supply connector is located at the upper left side of MX4660 (“CN2” in Figure 3). The power supply of the MX4660 can be connected as illustrated in Figure 4. Although MX4660’s working voltage is 20-60 VDC, we suggest the use of a 20-54 VDC power supply to leave room for back EMF voltage charge back during motor deceleration. Two pins design for up to 20A applications.

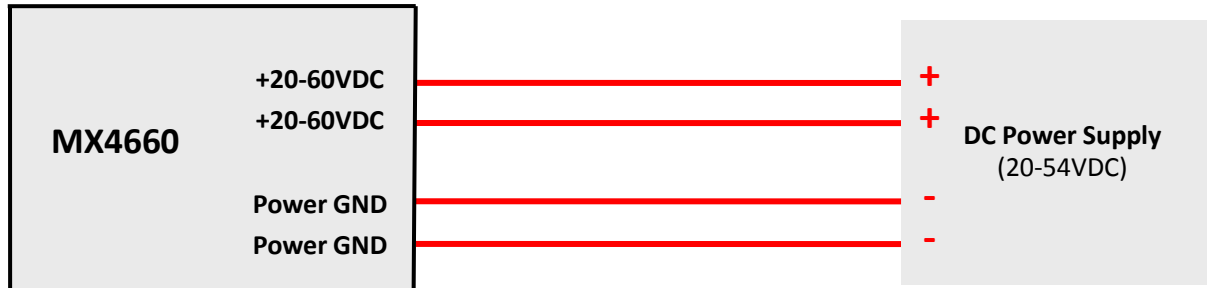

Figure 4 Power supply connections



- (1) *Never power on the power supply before finishing all the connections and configurations.*
- (2) *Make sure the two power supply leads, + & -, are correctly connected to the MX4660 power connector. Wrong connection will destroy the MX4660 and void its warranty.*
- (3) *Connecting a power supply with output voltage of 60VDC or up could damage the MX4660, and void its warranty.*

Connecting Stepper Motors

There are 4 stepper drive modules for the MX4660 to allow connections of up to four 2-phase stepper motors. Because of the wide output current range from 1.41 to 6.0A for each stepper drive module, the MX4660 can drive various stepper motors in frame sizes NEMA 17, 23, 24, and 34. You can find the 4 stepper drive module location at CN3, CN4, CN5 and CN6 on Figure 3. These stepper motors can be 4-lead, 6-lead, or 8-lead stepper motors.

To get the maximum torque from a stepper motor, the output current required from a stepper drive equals to the motor phase current multiplied by 1.4. Higher output current from a stepper drive module will result the stepper motor torque; but that also increase the motor heating. Therefore, it is recommended to set “just-enough” output put current to get the needed torque, and as less motor heating as possible.

Connecting a 4-Lead Stepper Motor

A 4 lead motor is the easiest to connect, and its speed-torque performance depends on its motor inductance. Refer to the wiring diagram of your stepper motor, and connect its wires to the motor connector to one of the MX4660 stepper drive module. Refer to Figure 5 below.

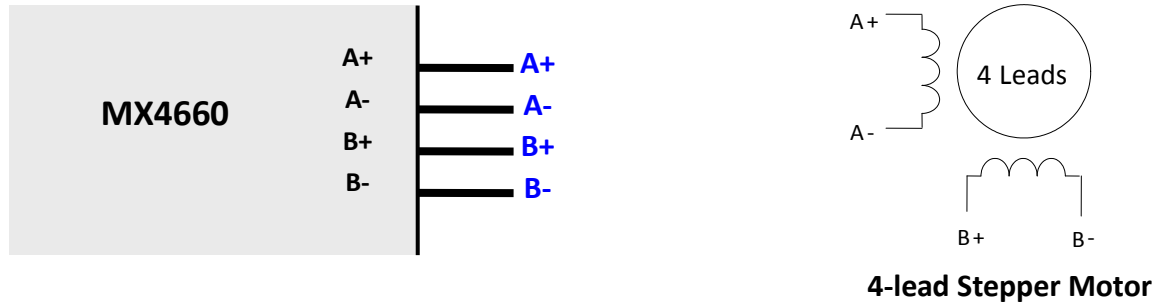

Figure 5 Connecting a 4-lead stepper motor

Connecting a 6-Lead Stepper Motor

The MX4660 can drive 6-lead stepper motors in either half coil connection or full coil connection. Before the connection, please read the datasheet of your stepper motor.

Connecting a 6-Lead Stepper Motor in series connection

This configuration is also referred to as half chopper. When connecting a 6-lead stepper motor, the half coil configuration uses 50% of the motor phase windings. This results in lower inductance, and hence lower torque output at low-speed movements. Like the parallel connection of an 8 lead motor, this connection is commonly used in applications requiring better high-speed torque performance. Refer to Figure 6 on next page for the connection.

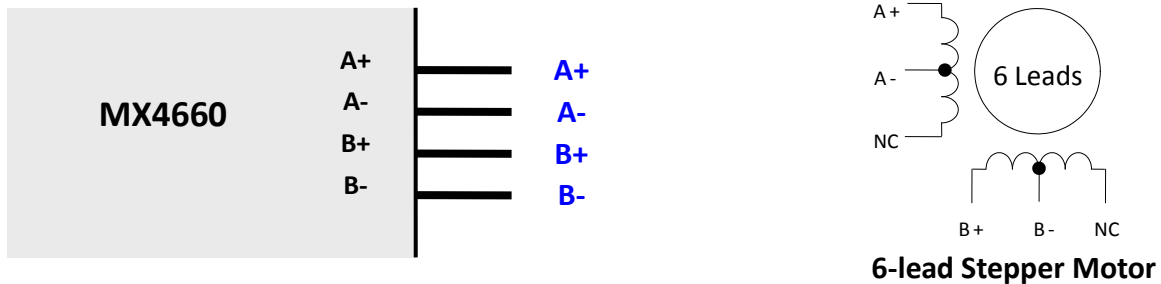

Figure 6 Connecting a 6-lead stepper motor in half-coil

Connecting a 6-Lead Stepper Motor in series connection

This configuration is also referred to as full copper. The full coil connection for a six lead motor is commonly used in applications requiring for higher torque performance at lower-speed movements. Refer to Figure 7 for the connection.

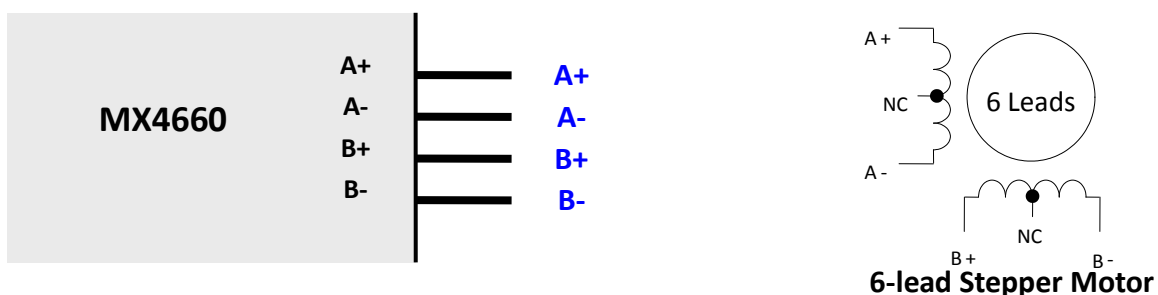

Figure 7 Connecting a 6-lead stepper motor in full coil

Connecting a 8-Lead Stepper Motor

The MX4660 can drive an 8-lead stepper motor in either series connection or parallel connection. Before the connection, please read the datasheet of your stepper motor.

Connecting a 8-Lead Stepper Motor in series connection

Refer to the wiring diagram of your stepper motor datasheet. Figure 8 illustrates how to connect an 8-lead stepper motor to the MX4660 in series connection.

An 8-lead stepper motor in series connection requires less current, so the motor coils can be charged quicker and achieves peak output torque faster than the same motor connected in parallel connection. This makes series connection preferable for applications that require higher torque at lower speed. But on the other side, because of its higher inductance, 8-lead stepper motor in series connection generates more motor heating and its higher speed torque performance is not good as a parallel connected stepper motor. It is recommended for not setting drive current no more than 70% of its rated current to prevent too much heating for a series connected 8-lead stepper motor, but what current to set is application dependent and at a user's choice.

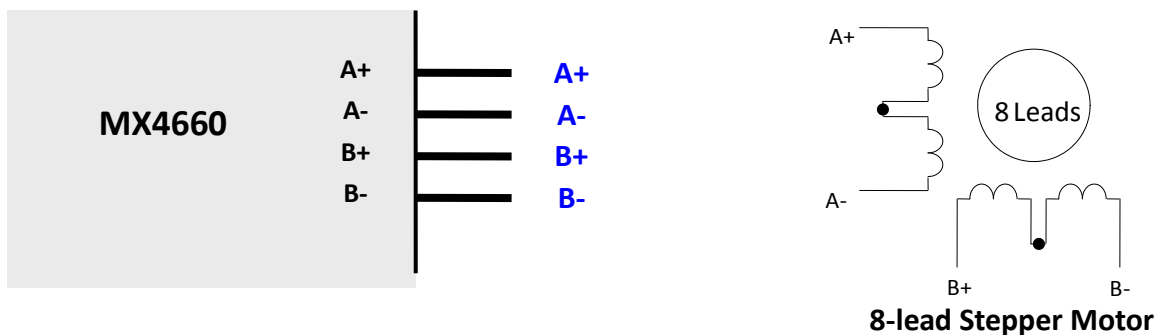

Figure 8 Connecting an 8-lead stepper motor in series connection

Connecting a 8-Lead Stepper Motor in Parallel Connection

Refer to the wiring diagram of your stepper motor datasheet. Figure 9 illustrates how to connect an 8-lead stepper motor to the MX4660 in parallel connection.

Due to the lower inductance for an 8-lead stepper motor in parallel connection, its high speed torque drops slower (*"better high-speed torque"*) than in series connection during higher speed motor rotation. This makes parallel connection preferred for applications runs in high speeds constantly such as CNC routers. Due to the parallel connected stepper motor will draw more current, thus it also has high requirements for the powering stepper drive. Fortunately, the maximum 6.0A output for each of four stepper drive module will allow MX4660 to drive stepper motors up to NEMA 34 in parallel connection.

Theoretically, to get the maximum torque of a parallel connected 8-lead stepper motor, you should multiply the phase current by 1.4. But it is suggested to set a "just enough" lower value to prevent too much heating from your stepper motor.

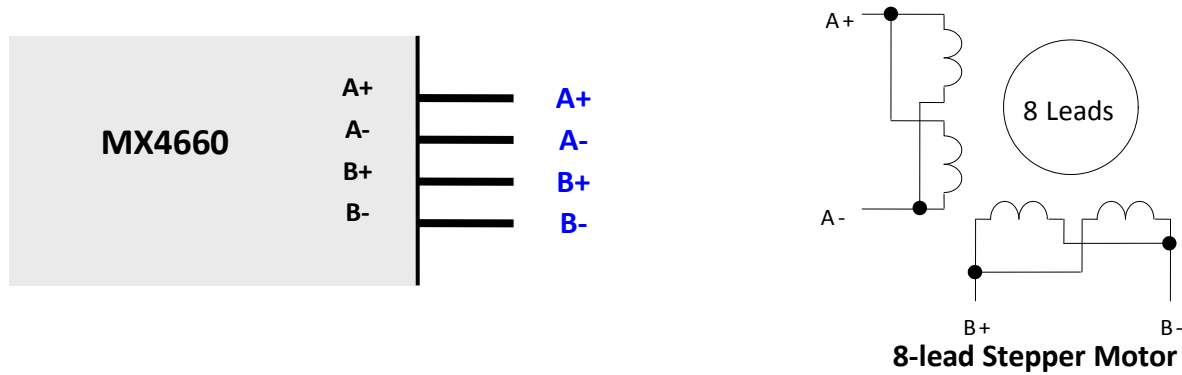

Figure 9 Connecting an 8-lead stepper motor in parallel connection



Never connect or disconnect a stepper motor while the power is on.

Connecting an E-Stop Switch or Shorting the Connection

The E-Stop connection is required. The E-Stop connector is located next to the power connector (Figure 3). **By default, the MX4660’s activation requires an emergency stop switch connected, or having the two connection pins, “ESTOP+” and “ESTOP-”, shorted.**

Refer to Figure 10 for how to connect an” E-Stop switch. To short the E-Stop connection, just connect a signal wire between the “ESTOP+” and “ESTOP-” pins.

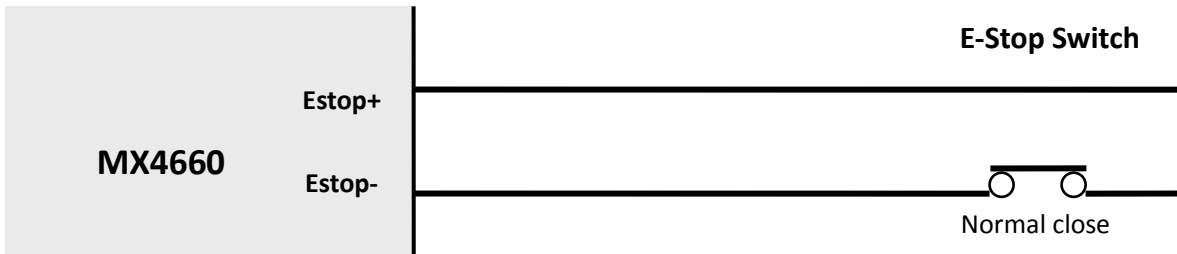

Figure 10 E-stop switch connections



Without the a E-STOP switch connected, or short circuit between Estop+ and Estop- pins, the red LED lights of the 4 stepper drive modules will blink 3 times periodically when MX4660 is powered on

Enabling / Disabling Charge Pump

To make MX4660 working properly, setting this switch to the right position is required. The MX4660 is featured with a feature called “Charge Pump”, a watchdog timer to enable/disable the MX4660. When the charge pump feature is turned on, the MX4660’s activation will depend on the receiving of 10 KHz signals at pin 16 of the DB25 connector. When the “Charge Pump” feature is turned off, the MX4660 will be activated without such verification.

By default, the charge pump feature is turned on, with the “Charge Pump” set to the “OFF” position (means “Charge Pump” ON). To disable this feature and make MX4660 to work with control systems (e.g. PLC, motion controller, etc.) not designed to use the “Charge Pump” feature, set the “Charge Pump” to “ON” position (meaning “Charge Pump” OFF).

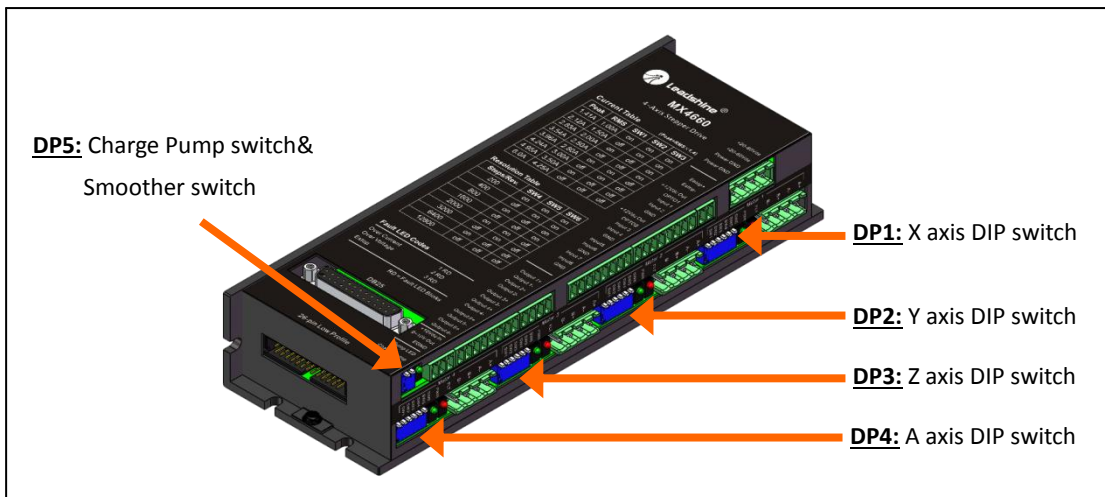

Figure11 MX4660 DIP switch locations

Setting the “Smoother” Switch

The firmware of each of the four stepper drive modules in the MX4660 adopts a feature called “smoothing” to smooth input step signals. When an input pulse emulated by the connected motion controller or CNC control system are not in linear or equivalent width, called “noise pulse”, it will cause erratic motion and additional motor/drive noise. Turning on the built-in digital smoother will trigger the input pulse train smoothing and could potentially improve motion performance such as less jittering, higher torque, and quicker response. Because of the complexity for different machines/devices, the “Smoother” feature may or may not have obvious effect (but at least no hurt for the bottom line). Turning on this switch or off is totally your choice. By default, the MX4660 smoother is set to off.

Configuring Output Current and Micro Step

The MX4660 allows individual settings of the output current and micro step resolution for each stepper motor, via the 6-pin DIP switches of four stepper drive modules (DP1, DP2, DP3 and DP4 on Figure 11).

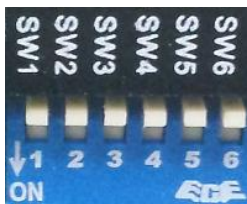

Figure 12 DIP switch for current & micro step configurations

Configuring Output Current

The output current configuration is required. Use SW1, SW2, and SW3 of the 6-pin DIP switch (Figure 12) of a stepper drive module to configure the output current to the driven stepper motor. Refer to Table 1 for available output current settings.

Peak	RMS	SW1	SW2	SW3
1.41A	1.00A	on	On	On
2.12A	1.50A	off	On	On
2.83A	2.00A	on	Off	On
3.54A	2.50A	off	Off	On
3.96A	2.80A	on	On	Off
4.24A	3.00A	off	On	Off
4.95A	3.50A	on	Off	Off
6.0A	4.25A	off	Off	Off

Table 1 output current settings for a stepper drive module

Configuring Micro Step Resolution

The micro step resolution configuration is required. Use pin 4, 5, and 6 of the 6-pin DIP switch (Figure 12) of a stepper drive module to configure the micro step resolution for the driven stepper motor. Refer to Table 2 for available micro step resolution settings.

Micro Step	Steps/Rev	SW4	SW5	SW6
Full	200	On	On	On
Half	400	Off	On	On
1 / 4	800	On	Off	On
1 / 8	1600	Off	Off	On
1 / 10	2000	On	On	Off
1 / 16	3200	Off	On	Off
1 / 32	6400	On	Off	Off
1 / 64	12800	Off	Off	Off

Table2 Micro step settings for a stepper drive module

Connecting the DB25 Connector

Refer to “**Appendix A**” for detail specification for the MX4660 DB25 connector pin-out. The DB25 connector is used to connect, directly / indirectly (e.g. via a circuit board), to a source of control signals (“controller” hereafter) such as a motion controller, a PLC, an indexer, PC-based control system (e.g. Mach 3, Mach4, EMC, WinCNC, etc.).

The controller is the “Brain” of the whole motion control system for: (1) sending signals of step, direction, and charge pump, to control the MX4660; (2) sending digital/analog signals for the controls of external devices, which are connected at the MX4660 digital output connector; (3) accepting “Fault” output from the MX4660; (4) take input signals sent from the external devices connected at the MX4660 digital input connector.

We will only depict the pin connections for step & direction, fault output, charge pump, and PWM. Refer to **Appendix A** for pin outs for other optional I/O’s

Connecting the DB25 Step & Direction Pins

The step and direction pin connections are required. Step signals are sent to MX4660 via pin 2, 4, 6, 8 of the DB25 connector. Direction signals are sent to MX4660 via pin 3, 5, 7, 9. Refer to Figure 13.

Step and direction signal voltage should be 3.3-5 VDC and “Active High”. In the controller configuration, the step width should be configured to a value at least 2.5 μ S, and direction setup time needs to be at least 4 μ S. Otherwise, it could cause loss of steps, or no motion at all for the controlled stepper motors.

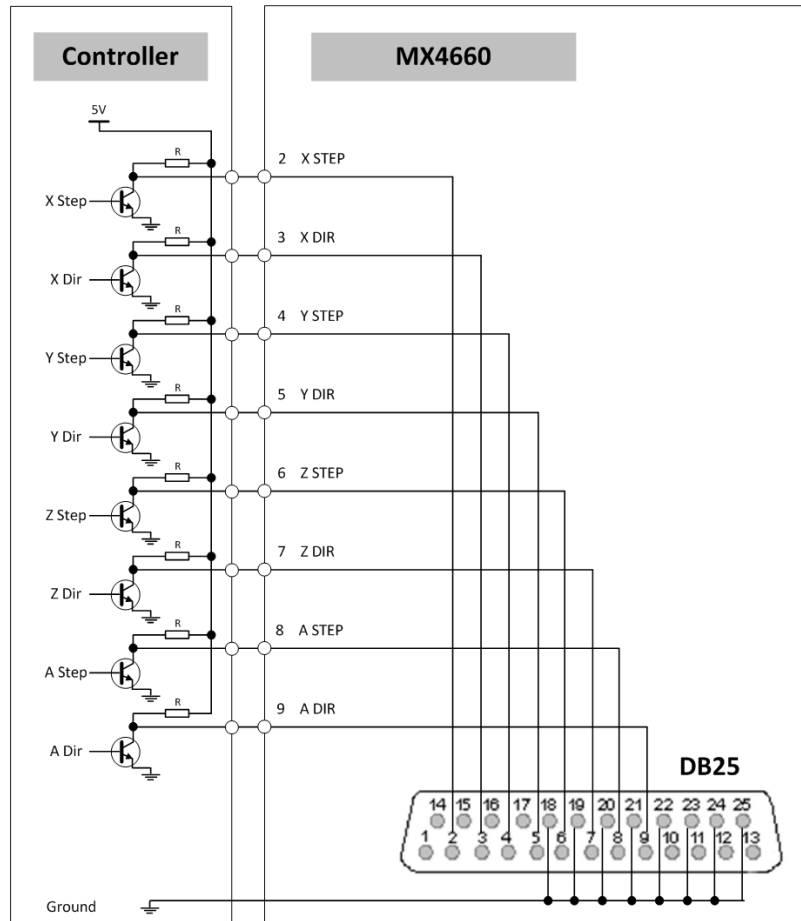

Figure 13 Connecting the step & direction signals of a controller to the MX4660



If step & direction signal voltage is lower than 5 VDC, you may need to increase step width and direction setup time (> 4 μ S) to move your motors, or avoid loss of step.

Connecting the DB25 Fault Output Pin

The fault pin connection is optional. The MX4660 4-Axis stepper drive will send a “Fault” output signal of 5 VDC back to the controller via Pin 15 (Appendix A) of the DB25 connector, in one of the following scenario:

- Any of the 4 stepper drive module is in protection mode including over voltage and over current. Read “Protection” detail in the MX4660 datasheet.
- The connected external E-Stop switch in the digital input is pressed.

With the receiving of a fault received from the MX4660, a controller can be notified an abnormal event has happened. It can then react, such as shutting down the whole control machine/device for machine damage.

Connecting the DB 25 Charge Pump Pin

The charge pump pin connection is optional. To implement the “Charge Pump” feature of the MX4660 4-Axis stepper drive, turn off the Charge Pump (page 12) and keep sending 10 KHz signals to Pin 16 of the DB25 connector while the controller works properly. In this scenario, the “Charge Pump LED” on the MX4660 will be turned on to indicate that everything is fine. When no such signal received, MX4660 will be disabled with the “Charge Pump LED” light off, to prevent from any further action caused by controller malfunction for connected stepper motors and external devices. Read “Enabling / Disabling Charge Pump” on page 12 for additional information.

Connecting the DB25 PWM Pin

The PWM pin connection is optional. The MX4660 can take PWM signals from the controller, through Pin 14 of the DB25 connector, transform it into an analog signal, and output as analog voltage signal at the “0-10V” pin of the analog output connector (Figure 3). This will allow the control of an external analog device such as a VFD for spindle speed control in a CNC router.

Optional Connections for Inputs/Outputs

The MX4660 4-Axis stepper drive is equipped with 8 built-in digital inputs, 6 digital outputs, and one 0-10 V analog output. Those connections are totally optional and not required to make the MX4660 work.

Connecting the Digital Inputs

The digital input connections are optional. The 8 general digital inputs are located at the Digital Input Connector (Figure 3) of the MX4660. They are named as Input 1, Input 2, Input 3, Input 4, Input 5, Input 6, Input 7 and Input 8. They can be used for any purpose such as connecting limit/home switches.

Input5, 6, 7, 8 are 12V sourcing (10mA MAX). Connect one end of your device wire to the “Input X” (X can be 5, 6, 7, or 8) pin, and the other wire to “GND” pin next to the input pin (for one wire device, short it to GND).

On Figure 14, it shows how to connect a home/limit switch to digital input “Input 5” to “input 8”. Refer to figure 16 for more information about their interface circuit.

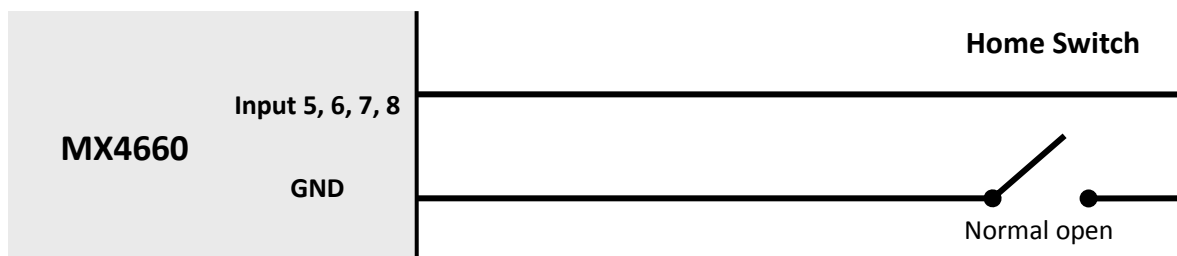

Figure 14 Home / limit switch connections to Input5-8 of the MX4660

Pulled up voltage or the power voltage of the opto-couplers for **Input1, Input2, Input3, Input4** is adjustable, depending on the input voltage of OPTO1 and OPTO2. **Do remember to connect the power grounds together (common ground) if use two different power supplies for OPTO1 and OPTO2. Or else, it may damage the drive because grounds (GNDs) for Input1, Input2, Input3, Input4 inside of the MX46660 are NON-isolated.**

This design makes digital inputs can work with external devices NOT only rated at 12 VDC with higher reliability and more flexibility, such as working with proximity sensors rated at different voltages. Figure 15 shows how to

connect these inputs and their interface circuit. See “Appendix A: MX4660 Connection Diagram” on page 20 for more information.

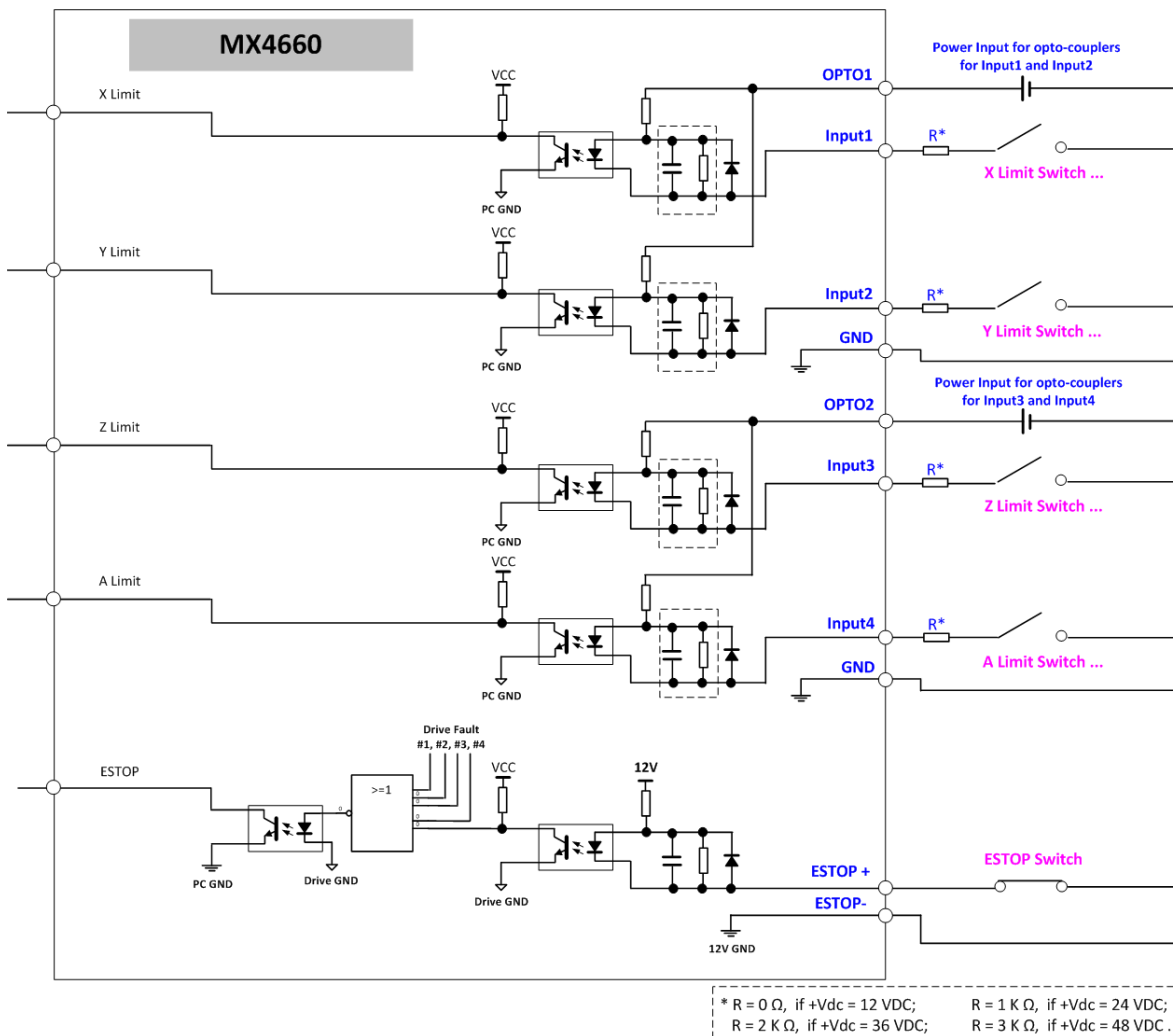

Figure 15 Home / limit switch connections to Input1-4 of the MX4660

Connecting the Digital Outputs

The digital Output Connections are optional. The 6 general digital outputs are located at the Digital Output Connector (Figure 3) of the MX4660, named as Output 1, Output 2, Output 3, Output 4, Output 5 and Output 6. They can be used to control a DC relay for coolant in a CNC router, or for other purpose such as expanding the 5th and 6th axis.

Output 1 and Output2 are connected to **Pin 17, 1** of the **DB25 connector** respectively, and **Output 3, Output 4, Output 5 and Output 6** are connected to **Pin 17, 1, 8, and 9** of the **26-pin low profile connector** respectively. Connect one end of the load to “Output X+” (X can be 1, 2, 3, 4, 5, 6, 7 or 8) pin and the other end to the VDC+ of a 5-24VDC power source. Then, connect the related “Output X-” pin of MX4660 to the power supply VDC-. Those digital outputs are rated at max 70mA. Refer to figure 21 of “MX4660 Connection Diagram” on page20 for using high speed digital output to expand the 5th axis.

Notice that the maximum frequency of the Output 1, Output 2, Output 3 and Output 4 is 200 kHz, and that of the Output 3 and Output 4 is 20 kHz. Do remember to connect the power grounds together (common ground)

if use two or more different power supplies (pull up) for Output 1+, Output 2+, Output 3+ and Output 4+. Or else, it may damage the drive because grounds (Output 1-, Output 2-, Output 3- and Output 4-) for Output 1, Output 2, Output 3 and Output 4 inside of the MX4660 are NON-isolated.

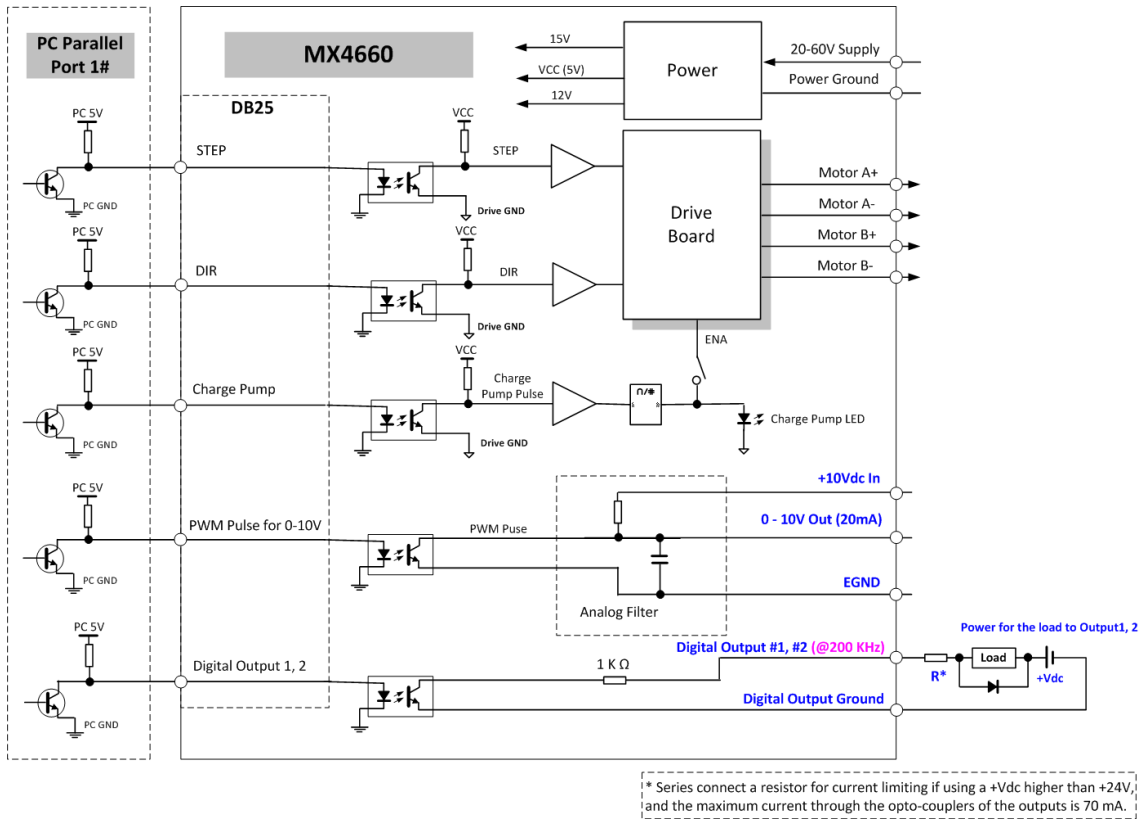

Figure 16 Connecting digital output1, 2

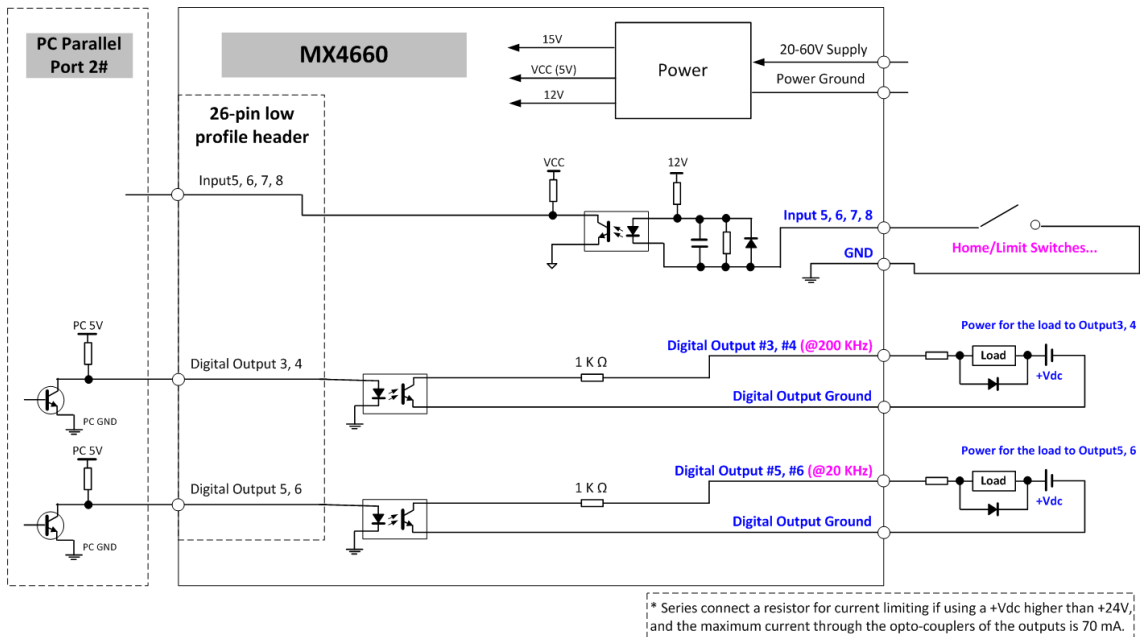

Figure 17 Connecting digital output3, 4, 5, 6

Connecting the Analog Output

The analog output connection is optional. The MX4660 4-Axis stepper drive also comes with an opto-isolated analog output (Figure 3) to allow control of an external analog device, such as a VFD for spindle control. Supply voltage for the analog device is 5-15 VDC, and the output voltage signal is 0 to (Analog Supply Voltage minus 1.1 VDC).

On Figure 18, it shows how to connect a VFD to the opto-isolated analog output. Connect the VFD 10 VDC power wire to “+10 VDC” pin, “Input” wire to “0-10V”, and GND wire to “GND”. Refer to figure 16 for more information about their interface circuit.

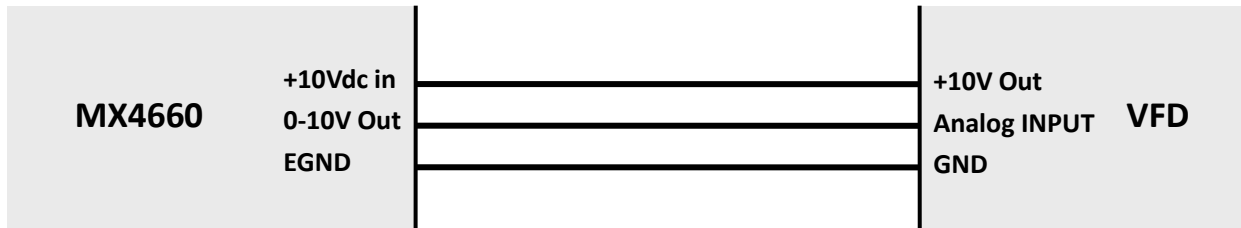

Figure 18 Connecting a VFD to the MX4660

Figure 19 shows the relationship of the spindle speed output in Mach3 and analog output of the MX4660.

Testing conditions:

- (1) Used MACH3, settings: PWMBase Freq. = 10, Minimum PWM = 0%,
- (2) Used “+12Vdc Out”, the 12VDC auxiliary power output on the MX4660 as the power input for “+10Vdc in” of the VFD (The measured value of the “+12VDC auxiliary power output of the MX4660” was: 11.98VDC.).
- (3) Device for measuring voltage was Agilent digital oscilloscope DSO-X 3014A. (The raw data of the testing results is available on request.)

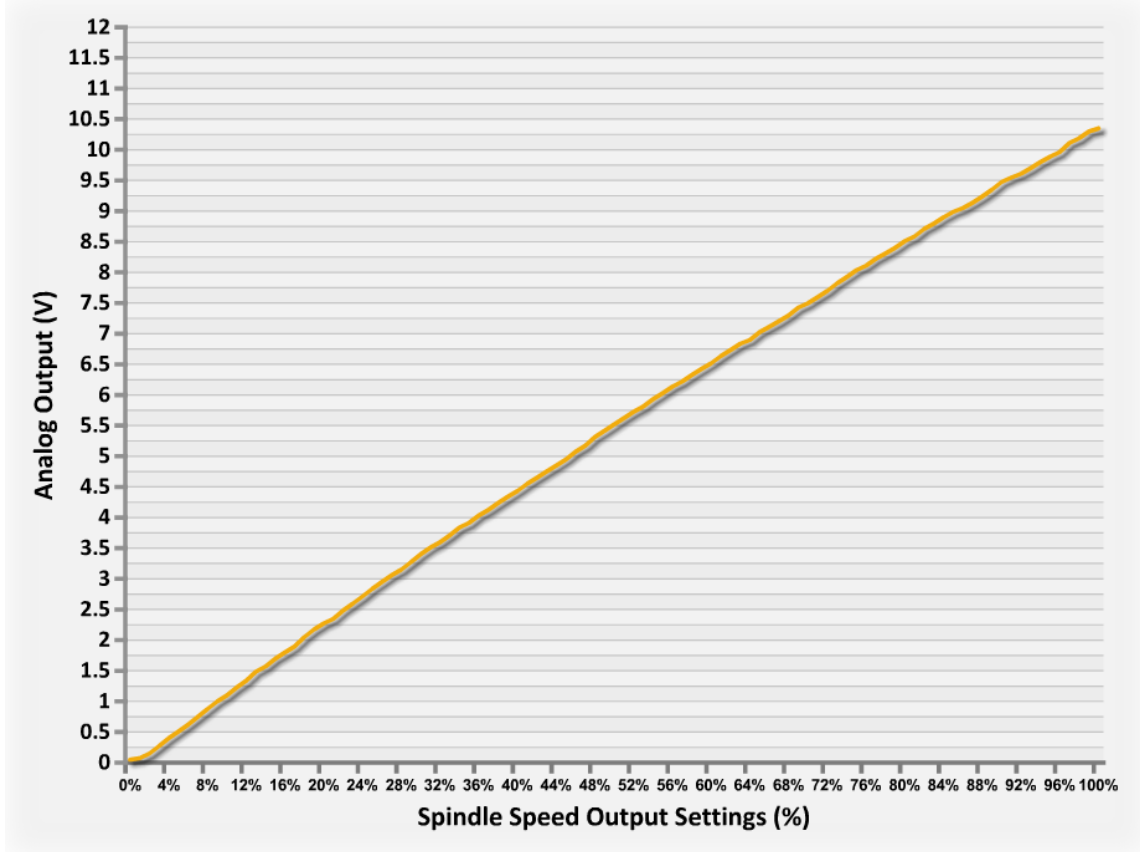

Figure 19 Spindle output & analog output of the MX4660

The precision of the analog output is related to PWMBase Freq. parameter settings. When set PWMBase Freq. = 80 Hz, the precision/resolution reached to +/- 11.875 mV. See below.

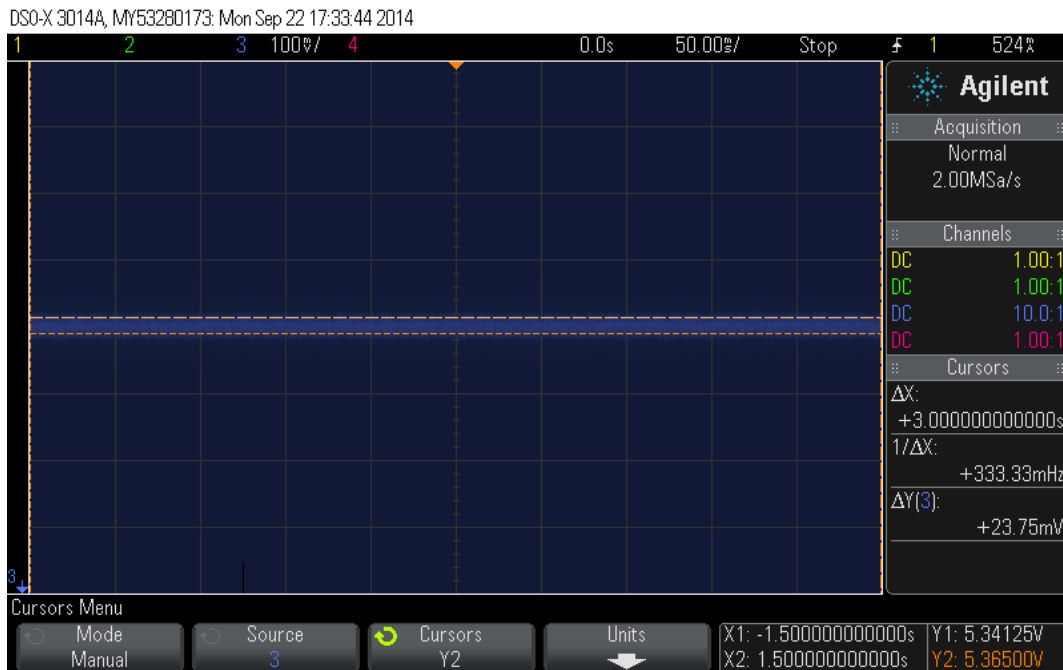

Figure 20 PWMBase Freq. parameter settings & analog output precision

Appendix A: MX4660 Connection Diagram

When implemented properly, the MX4660 can be used to power four 2 phase (1.8°) stepper motors of NEMA 17, 23, 24, and 34. In addition, it can also allow controls of optional external devices via the built-in digital inputs, digital outputs, and the opto-isolated analog output. Figure 21 illustrates the MX4660 connection diagram with 4 stepper motors. External devices through the MX4660 I/O connections are optional at a user’s choice. **If you need to use input5, input6, input7, input8, output3, output4, output5 and output6, a 2nd parallel port or an external device like SmoothStepper is required.**

NOTE: For higher reliability, it is suggested to add a shunt regulator with the DC power supply to discharge the energy/ back-EMF generated during rapid deceleration or in case of emergency when have to push the E-stop button when the motors are running. Or even add 2 big capacitors between +20-60VDC and Power GND will be helpful if a shunt regulator is not available. See more information in Page 8 of the hardware manual for the MX4660.

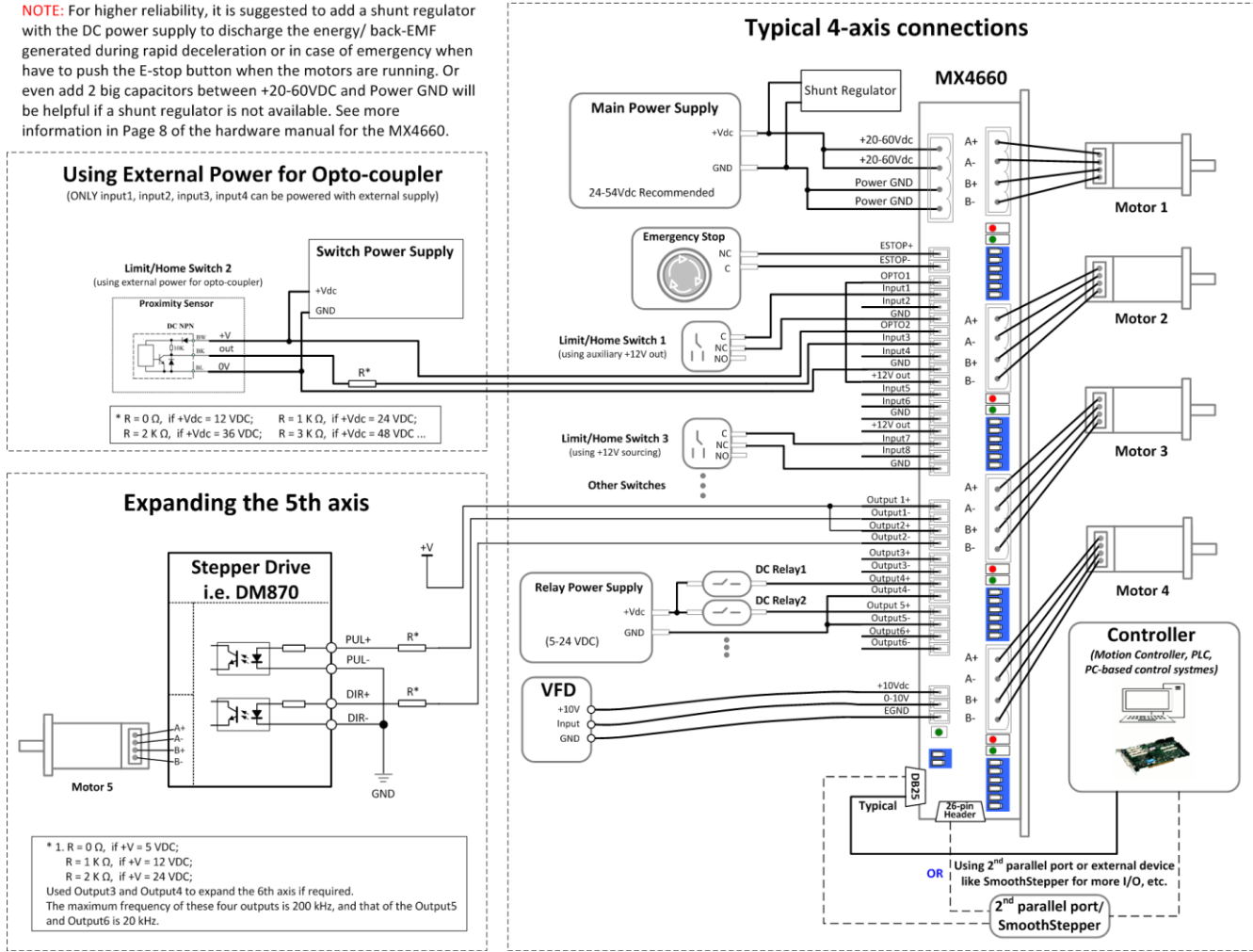

Figure 21 MX4660 Connection Diagram

Appendix B: DB25 Connector Pinout

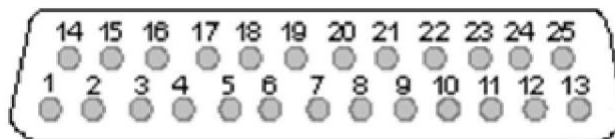

Figure 22 DB25 connector pin assignments

Pin	Name	Description
1	INPUT 2	<u>General purpose digital input.</u> It is connected to “Output 2” of the digital output connector (CN8 on Figure3). Used to forward an input signal sent from the connected motion controller to the device connected at “Output 2”.Its maximum frequency up to 200 kHz.
2	X-AXIS STEP	<u>Input step signal</u> for the X-axis stepper drive board.
3	X-AXIS DIRECTION	<u>Input direction signal</u> for the X-axis stepper drive board.
4	Y-AXIS STEP	<u>Input step signal</u> for the Y-axis stepper drive board.
5	Y-AXIS DIRECTION	<u>Input direction signal</u> for the Y-axis stepper drive board.
6	Z-AXIS STEP	<u>Input step signal</u> for the Z-axis stepper drive board.
7	Z-AXIS DIRECTION	<u>Input direction signal</u> for the Z-axis stepper drive board.
8	A-AXIS STEP	<u>Input step signal</u> for the A-axis stepper drive board.
9	A-AXIS DIRECTION	<u>Input direction signal</u> for theA-axis stepper drive board.
10	OUTPUT 1	<u>General purpose digital output.</u> It is connected to “Input 1” of the digital input connector (CN7 on Figure3). Used to forward an output signal from the device connected at “Input 1”, to the motion controller.
11	OUTPUT2	<u>General purpose digital output.</u> It is connected to “Input 2” of the digital input connector (CN7 on Figure3). Used to forward an output signal from the device connected at “Input 2”, to the motion controller.
12	OUTPUT3	<u>General purpose digital output.</u> It is connected to “Input 3” of the digital input connector (CN7 on Figure3). Used to forward an output signal sent from the device connected at “Input 3”, to the motion controller.
13	OUTPUT4	<u>General purpose digital output.</u> It is connected to “Input 4” of the digital input connector (CN7 on Figure3). Used to forward an output signal sent from the device connected at “Input 4”, to the motion controller.
14	PWM	<u>PWM pulse input.</u> Used to get the PWM signal from the controller which will be then transformed into an analog signal to an external device connected at “0-10V out” pin of the analog output connector (CN8 on Figure 3), such as a VFD for spindle speed control.
15	FAULT	<u>Fault signal output</u> back to a motion controller. It will beactivated (voltage high) when one of the following events occurs: (1) a signal from ESTOP; (2) any of the 4 built stepper drive modules fails, or is activated for protection.
16	CHARGE PUMP	<u>General digital input.</u> A watchdog timer to disable/enable the MX4660. When “Charge Pump” (Figure5) is set to “OFF” position (Charge pump feature NOT turned off), the MX4660 will be only enabled with 10 KHz signal receiving at this PIN. Otherwise (no such signal received), the MX4660 will be disabled, and you need to set the switch to “ON” position if the user would like to operate/enalbe the drive without such singal received. For example, in Mach3 controlled CNC applications, MX4660’s enabling/disabling will depend on the receiving of “Charge Pump” signal from Mach 3. When the MX4660 is enabled, Charge Pump LED will be on.
17	INPUT 1	<u>General purpose digital input.</u> It is connected to “Output 1” of the digital output connector (CN8 on Figure3). Used to forward an input signal sent from the connected motion controller to the device connected at “Output1”.Its maximum frequency up to 200 kHz.

Pin	Name	Description
18	GND	Ground
19	GND	Ground
20	GND	Ground
21	GND	Ground
22	GND	Ground
23	GND	Ground
24	GND	Ground
25	GND	Ground

Appendix C: 26-pin Low-profile Connector Pinout

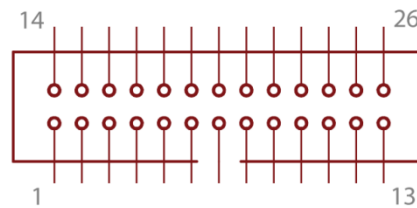

Figure 23 Pin assignments of the 26-pin low-profile connector

Pin	Name	Description
1	INPUT 6	<u>General purpose digital input.</u> It is connected to “Output 6” of the digital output connector (CN7 on Figure3). Used to forward an input signal sent from the connected motion controller to the device connected at “Output6”. Its maximum frequency up to 20 kHz.
2	NC	<u>Not connected.</u>
3	NC	<u>Not connected.</u>
4	NC	<u>Not connected.</u>
5	NC	<u>Not connected.</u>
6	NC	<u>Not connected.</u>
7	NC	<u>Not connected.</u>
8	INPUT3	<u>General purpose digital input.</u> It is connected to “Output 3” of the digital output connector (CN8 on Figure3). Used to forward an input signal sent from the connected motion controller to the device connected at “Output3”. Its maximum frequency up to 200 kHz.
9	INPUT 4	<u>General purpose digital input.</u> It is connected to “Output 4” of the digital output connector (CN7 on Figure3). Used to forward an input signal sent from the connected motion controller to the device connected at “Output4”. Its maximum frequency up to 200 kHz.
10	OUTPUT5	<u>General purpose digital output.</u> It is connected to “Input 5” of the digital input connector (CN7 on Figure3). Used to forward an output signal from the device connected at “Input 5”, to the motion controller.
11	OUTPUT6	<u>General purpose digital output.</u> It is connected to “Input 6” of the digital input connector (CN7 on Figure3). Used to forward an output signal from the device

		connected at “Input 6”, to the motion controller.
12	OUTPUT7	<u>General purpose digital output.</u> It is connected to “Input 7” of the digital input connector (CN7 on Figure3). Used to forward an output signal sent from the device connected at “Input 7”, to the motion controller.
13	OUTPUT8	<u>General purpose digital output.</u> It is connected to “Input 8” of the digital input connector (CN7 on Figure3). Used to forward an output signal sent from the device connected at “Input 8”, to the motion controller.
14	NC	<u>Not connected.</u>
15	NC	<u>Not connected.</u>
16	NC	<u>Not connected.</u>
17	INPUT 5	<u>General purpose digital input.</u> It is connected to “Output 5” of the digital output connector (CN7 on Figure3). Used to forward an input signal sent from the connected motion controller to the device connected at “Output5”. Its maximum frequency up to 20 kHz.
18	GND	Ground
19	GND	Ground
20	GND	Ground
21	GND	Ground
22	GND	Ground
23	GND	Ground
24	GND	Ground
25	GND	Ground
26	GND	Ground
26	GND	Ground

Appendix D: Digital Inputs

Name	Description
Estop+	<u>Emergency stop input</u> (12V Sourcing). When activated, all four drive boards will be shut down and the MX4660 will stop working. The red LED of each drive module will blink three times periodically every 4 seconds to indicate an emergency event signal received. In this case, a fault output will be sent to pin 15 - “Fault”- of the DB25 connector to notify the connected motion controller.
Estop-	Common ground
OPTO1	Power Input for opto-couplers for Input1 and Input2. Default is +12VDC and a +12Vdc Out is available on board. A resistor isrequired for current limit when inputvoltage is higher than +12 VDC. See figure 15 for more information. This design makes digital inputs can work with external devices NOT only rated at 12 VDC with higher reliability and more flexibility, such as working with proximity sensors rated at different voltages. Do remember to connect the power grounds together (common ground) if use two different power supplies for OPTO1 and OPTO2. Or else, it may damage the drive because grounds (GNDs) for Input1, Input2, Input3, Input4 inside of the MX46660 are NON-isolated.
Input 1	<u>General Purpose Input.</u> This pin is connected to pin 10 - “Output 1” - of the DB25 connector. Used to forward the digital output signal, sent from the connected external device here, to the motion

	controller connected through the DB25 connector.
Input 2	<u>General purpose Input</u> . This pin is connected to pin 11 - “Output 2” - of the DB25 connector. Used to forward the digital output signal, sent from the connected external device here, to the motion controller connected through the DB25 connector.
GND	Common ground.
OPTO2	Power Input for opto-couplers for Input1 and Input2. Default is +12VDC and a +12Vdc Out is available on board. A resistor is required for current limit when input voltage is higher than +12 VDC. See figure 15 for more information. This design makes digital inputs can work with external devices NOT only rated at 12 VDC with higher reliability and more flexibility, such as working with proximity sensors rated at different voltages. Do remember to connect the power grounds together (common ground) if use two different power supplies for OPTO1 and OPTO2. Or else, it may damage the drive because grounds (GNDs) for Input1, Input2, Input3, Input4 inside of the MX46660 are NON-isolated.
Input 3	<u>General Purpose Input</u> . This pin is connected to pin 12 - “Output 3” - of the DB25 connector. Used to forward the digital output signal, sent from the connected external device here, to the motion controller connected through the DB25 connector.
Input 4	<u>General purpose Input</u> . This pin is connected to pin 13 - “Output 4” - of the DB25 connector. Used to forward the digital output signal, sent from the connected external device here, to the motion controller connected through the DB25 connector.
GND	Common ground
+12Vdc Out	Auxiliary power output (+12V @ 100mA). This auxiliary power outputs can be used as an input for OPTO1 or OPTO2.
Input 5	<u>General purpose Input (12V sourcing)</u> . This pin is connected to pin 10 - “Output 5” - of the 26-pin low-profile header. Used to forward the digital output signal, sent from the connected external device here, to the motion controller connected through the 26-pin low-profile header. A 2 nd parallel port or an external device like SmoothStepper is required for this function.
Input 6	<u>General purpose Input (12V sourcing)</u> . This pin is connected to pin 11 - “Output 6” - of the 26-pin low-profile header. Used to forward the digital output signal, sent from the connected external device here, to the motion controller connected through the 26-pin low-profile header. A 2 nd parallel port or an external device like SmoothStepper is required for this function.
GND	Common ground
+12Vdc Out	Auxiliary power output (+12V @ 100mA). This auxiliary power outputs can be used as an input for OPTO1 or OPTO2.
Input 7	<u>General purpose Input (12V sourcing)</u> . This pin is connected to pin 12 - “Output 7” - of the 26-pin low-profile header. Used to forward the digital output signal, sent from the connected external device here, to the motion controller connected through the 26-pin low-profile header. A 2 nd parallel port or an external device like SmoothStepper is required for this function.
Input 8	<u>General purpose Input (12V sourcing)</u> . This pin is connected to pin 13 - “Output 8” - of the 26-pin low-profile header. Used to forward the digital output signal, sent from the connected external device here, to the motion controller connected through the 26-pin low-profile header. A 2 nd parallel port or an external device like SmoothStepper is required for this function.
GND	Common ground

Appendix E: Digital Outputs

Name	Description
Output 1 +	<u>General purpose output</u> (max 24V@70mA). This pin is connected to pin 17 - "Input 1" - of the DB25 connector. Used to output the digital signal, sent through DB25 "Input 1" from the motion controller, to the connected external device here. Its maximum frequency is 200 kHz. Do remember to connect the power grounds together (common ground) if use two or more different power supplies (pull up) for Output 1+, Output 2+, Output 3+ and Output 4+. Or else, it may damage the drive because grounds (Output 1-, Output 2-, Output 3- and Output 4-) for Output 1, Output 2, Output 3 and Output 4 inside of the MX46660 are NON-isolated.
Output 1-	<u>General purpose output-</u> for Output 1
Output 2 +	<u>General purpose output</u> (max 24V@70mA). The pin is connected to pin 1 - "Input 2" - of the DB25 connector. Used to output the digital signal, sent through DB25 "Input 2" from the motion controller, to the connected external device here. Its maximum frequency is 200 kHz. See "description for Output 1+" above for more information.
Output 2-	<u>General purpose output -</u> for Output 3
Output 3 +	<u>General purpose output</u> (max 24V@70mA). This pin is connected to pin 8- "Input 3" - of the 26-pin low-profile header. Used to output the digital signal, sent through 26-pin low-profile header "Input 3" from the motion controller, to the connected external device here. A 2 nd parallel port or an external device like SmoothStepper is required for this function. Its maximum frequency is 200 kHz. See "description for Output 1+" above for more information.
Output 3-	<u>General purpose output -</u> for Output 3
Output4 +	<u>General purpose output</u> (max 24V@70mA). This pin is connected to pin 9-"Input 4" - of the 26-pin low-profile header. Used to output the digital signal, sent through 26-pin low-profile header "Input 4" from the motion controller, to the connected external device here. A 2 nd parallel port or an external device like SmoothStepper is required for this function. Its maximum frequency is 20 kHz. See "description for Output 1+" above for more information.
Output 4-	<u>General purpose output -</u> for Output 4
Output 5+	<u>General purpose output</u> (max 24V@70mA). This pin is connected to pin 17 - "Input 5" - of the 26-pin low-profile header. Used to output the digital signal, sent through 26-pin low-profile header "Input 5 from the motion controller, to the connected external device here. A 2 nd parallel port or an external device like SmoothStepper is required for this function. Its maximum frequency is 200 kHz.
Output 5	<u>General purpose output -</u> for Output 5
Output 6+	<u>General purpose output</u> (max 24V@70mA). This pin is connected to pin 1 - "Input 6" - of the 26-pin low-profile header. Used to output the digital signal, sent through 26-pin low-profile header "Input 6 from the motion controller, to the connected external device here. A 2 nd parallel port or an external device like SmoothStepper is required for this function. Its maximum frequency is 20 kHz.
Output 6-	<u>General purpose output -</u> for Output 6

Appendix F: Opto-Isolated Analog Output

Name	Description
+10Vdc in	<u>External +10V power input.</u> Used for power supply connection for the external device (e.g. a VFD) connected at “0-10V” pin.
0-10V out	<u>Analog 0-10V output.</u> This pin is connected to Pin 14 of the DB25 connector. Used to forward the PWM signal, sent from the motion controller, to the connected external device. Read pin 14 - “PWM” - of the DB25 Connector for more information
EGND	<u>External +10V ground</u>

Appendix G: Stepper Drive Module Replacement

In the case that one of the four stepper drive modules of the MX4660 does not work (the green LED light is not on when the MX4660 is powered on) you can replace it with a Leadshine SDM660 stepper drive module. Contact us for getting a new SDM660.

Appendix H: Warranty Information

The MX4660 4-Axis stepper drive comes with 12-month limited warranty under proper use. Contact your MX4660 supplier first for warranty service. If your MX4660 was bought through Leadshine or one of its subsidiaries, contact us directly.

Appendix I: Trouble Shooting

In the case that the MX4660 doesn’t operate properly, the first step is to identify whether the problem is electrical or mechanical in nature. The next step is to isolate the system component that is causing the problem. As part of this process you may have to disconnect the individual components that make up your system and verify that they operate independently. It is important to document each step in the troubleshooting process. You may need this documentation to refer back to at a later date, and these details will greatly assist our Technical Support staff in determining the problem should you need assistance.

Many of the problems that affect motion control systems can be traced to electrical noise, controller software errors, or mistakes in wiring. The following table shows some commonly asked symptoms and possible solutions.

Symptoms	Possible Cause	Solution
A motor doesn’t move	No power	Connect Power
	Wrong signal and / or stepper motor connection	Correct the DB25 connector and / or stepper motor connection(s)
	No E-Stop connection	Option 1: connect an E-Stop switch. Or, Option 2: short “E-Stop +” and “E-Stop+” pins
	The stepper drive modules is under protection	Make sure the power supply voltage is not too high. Also look into your mechanic systems and make sure it does not cause over current protection.
	Control signal voltage is too low	Increase step width.

Appendix I: Trouble Shooting (Continued)

Symptoms	Possible Cause	Solution
Motor spins in wrong direction	Wrong motor wiring	Reverse wires on one phase of the stepper motor
Loss of steps	Wrong step enabling setting in your controller	By default, MX4660 step enabling is "Active High". Change your step enabling configuration of your controller to "Active High" also.
	Direction set up time is too short	Increase the direction set up time in your controller to at least 4 μ s.
	Frequency of the step signal is too high	Make sure the maximum frequency of the step signal is lower than 200 kHz.
	Interference	Shield your signal cables and keep the MX4660 as far as possible, from other electronic components
The red LED light of a stepper drive module blinks	Power supply voltage is too high	Use a lower voltage power supply (recommended input is 24-54 VDC)
	No E-Stop connection	Option 1: connect an E-Stop switch. Or, Option 2: short "E-Stop +" and "E-Stop+" pins
	Damaged stepper motor	Replace your stepper motor
	Over current protection caused by mechanic system	Check and fix the mechanic problem(s) from your mechanic system.
	Deceleration is too fast.	During deceleration, back EMF voltage charge has enabled drive "Over Voltage" protection. Lower down your acceleration/deceleration.
Excessive motor and drive heating	Load is too high	Use a larger motor or motors
	Mechanic problem	Check your mechanic system
	Bad heating dissipation	Add a fan or other device to improve air circulation
The green light of a drive module is not on	That stepper drive module is already damaged	Contact Leadshine for a new stepper drive module for replacement

Contact US

Contact Leadshine HQ, Leadshine USA Inc., or your local authorized Leadshine distributors for sales, technical support, and other services.

Leadshine Headquarters

Address: 11/F, Block A3, iPark
No.1001 Xueyuan Blvd.
Nanshan District, Shenzhen, China

Tel: 86-400-885-5521

Fax: 86-755-2640-2718

Web: www.leadshine.com

Sales Email: sales@leadshine.com

Support: tech@leadshine.com

Leadshine America, Inc.

Address: 25 Mauchly, Suite 318
Irvine, CA 92608
USA

Tel: 1-949-608-7270

Fax: 1-949-608-7298

Web: www.leadshineusa.com

Sales Email: sales@leadshineusa.com

Support: support@leadshineusa.com